

SOLAR INVERTER / CHARGER

MANUAL MF-OME-PRO12KW
(USER MANUAL)

Table of Contents

| | |
|---------------------------------------------------------|-----------|
| ABOUT THIS MANUAL | 1 |
| Purpose..... | 1 |
| Scope..... | 1 |
| SAFETY INSTRUCTIONS..... | 1 |
| INTRODUCTION | 2 |
| Features..... | 2 |
| Basic System Architecture | 2 |
| Product Overview..... | 3 |
| Unpacking and Inspection | 4 |
| Preparation | 4 |
| Mounting the Unit..... | 4 |
| Battery Connection | 5 |
| AC Input/Output Connection..... | 6 |
| PV Connection | 7 |
| Final Assembly..... | 10 |
| Communication Connection..... | 11 |
| OPERATION..... | 13 |
| Power ON/OFF | 13 |
| Inverter Turn-on | 13 |
| Operation and Display Panel | 13 |
| Human Interface Specification..... | 14 |
| Warning and Fault List..... | 28 |
| BATTERY EQUALIZATION | 29 |
| SPECIFICATIONS | 30 |
| Table 1 Line Mode Specifications | 30 |
| Table 2 Inverter Mode Specifications | 31 |
| Table 3 Charge Mode Specifications | 32 |
| Table 4 General Specifications..... | 33 |
| TROUBLE SHOOTING | 34 |
| Appendix I: Parallel function | 36 |
| Appendix II: BMS Communication Installation..... | 49 |
| Appendix III: The Wi-Fi Operation Guide..... | 55 |

ABOUT THIS MANUAL

Purpose

This manual describes the assembly, installation, operation and troubleshooting of this unit. Please read this manual carefully before installations and operations. Keep this manual for future reference.

Scope

This manual provides safety and installation guidelines as well as information on tools and wiring.

SAFETY INSTRUCTIONS

⚠ WARNING: This chapter contains important safety and operating instructions. Read and keep this manual for future reference.

1. Before using the unit, read all instructions and cautionary markings on the unit, the batteries and all appropriate sections of this manual.
2. **CAUTION** – To reduce risk of injury, charge only deep-cycle lead acid type rechargeable batteries. Other types of batteries may burst, causing personal injury and damage.
3. Do not disassemble the unit. Take it to a qualified service center when service or repair is required. Incorrect re-assembly may result in a risk of electric shock or fire.
4. To reduce risk of electric shock, disconnect all wirings before attempting any maintenance or cleaning. Turning off the unit will not reduce this risk.
5. **CAUTION** – Only qualified personnel can install this device with battery.
6. **NEVER** charge a frozen battery.
7. For optimum operation of this inverter/charger, please follow required spec to select appropriate cable size. It's very important to correctly operate this inverter/charger.
8. Be very cautious when working with metal tools on or around batteries. A potential risk exists to drop a tool to spark or short circuit batteries or other electrical parts and could cause an explosion.
9. Please strictly follow installation procedure when you want to disconnect AC or DC terminals. Please refer to INSTALLATION section of this manual for the details.
10. Fuses are provided as over-current protection for the battery supply.
11. GROUNDING INSTRUCTIONS -This inverter/charger should be connected to a permanent grounded wiring system. Be sure to comply with local requirements and regulation to install this inverter.
12. NEVER cause AC output and DC input short circuited. Do NOT connect to the mains when DC input short circuits.
13. **Warning!!** Only qualified service persons are able to service this device. If errors still persist after following troubleshooting table, please send this inverter/charger back to local dealer or service center for maintenance.
14. **WARNING:** Because this inverter is non-isolated, only three types of PV modules are acceptable: single crystalline, poly crystalline with class A-rated and CIGS modules. To avoid any malfunction, do not connect any PV modules with possible current leakage to the inverter. For example, grounded PV modules will cause current leakage to the inverter. When using CIGS modules, please be sure NO grounding.
15. **CAUTION:** It's required to use PV junction box with surge protection. Otherwise, it will cause damage on inverter when lightning occurs on PV modules.

INTRODUCTION

This is a multi-function inverter, combining functions of inverter, solar charger and battery charger to offer uninterruptible power support in a single package. The comprehensive LCD display offers user-configurable and easy-accessible button operations such as battery charging current, AC or solar charging priority, and acceptable input voltage based on different applications.

Features

- Pure sine wave inverter
- Configurable color with the built-in RGB LED bar
- Built-in Wi-Fi for mobile monitoring (APP is required)
- Supports USB On-the-Go function
- Built-in anti-dust kit
- Multiple communication ports for BMS (RS485, CAN-BUS, RS232)
- Configurable input voltage ranges for home appliances and personal computers via LCD control panel
- Configurable AC/PV output usage timer and prioritization
- Configurable AC/Solar charger priority via LCD control panel
- Configurable battery charging current based on applications via LCD control panel
- Compatible to utility mains or generator power
- Auto restart while AC is recovering
- Overload / Over temperature / short circuit protection
- Smart battery charger design for optimized battery performance
- Cold start function

Basic System Architecture

The following illustration shows basic application for this unit. It also required the following devices to have a complete running system:

- Generator or Utility mains.
- PV modules

Consult with your system integrator for other possible system architectures depending on your requirements.

This inverter can power various appliances in home or office environment, including motor-type appliances such as tube light, fan, refrigerator and air conditioners.

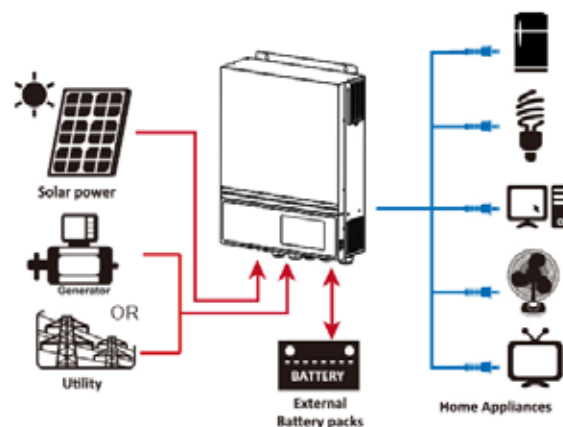

Basic PV System Overview

Product Overview

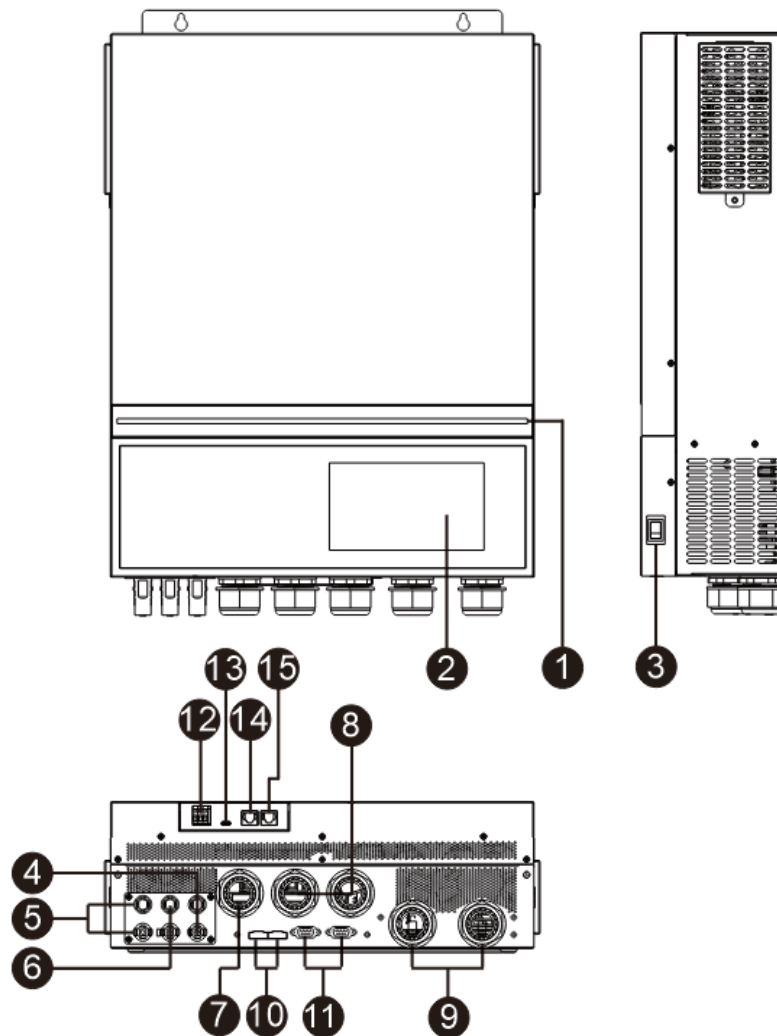

NOTE: For parallel installation and operation, please check *Appendix I*.

1. RGB LED bar (refer to LCD Setting section for the details)
2. LCD display
3. Power on/off switch
4. PV connectors(PV1)
5. PV connectors(PV2_1)
6. PV connectors(PV2_2)
7. AC input connectors
8. AC output connectors (Load connection)
9. Battery connectors
10. Current sharing port
11. Parallel communication port
12. Dry contact
13. USB port as USB communication port and USB function port
14. BMS communication port: CAN, RS-485 or RS-232
15. RS-232 communication port

Unpacking and Inspection

Before installation, please inspect the unit. Be sure that nothing inside the package is damaged. You should have received the following items inside of package:

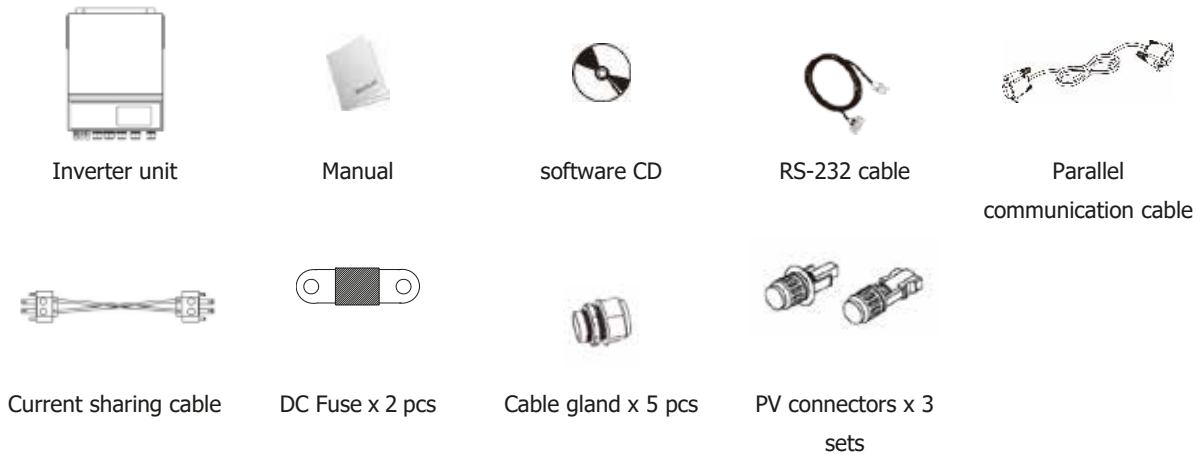

Preparation

Before connecting all wirings, please take off bottom cover by removing five screws. When removing the bottom cover, be carefully to remove three cables as shown below.

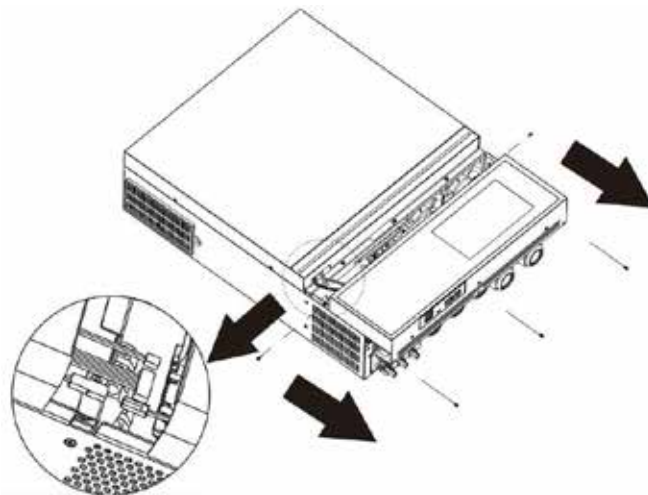

Mounting the Unit

Consider the following points before selecting where to install:

- Do not mount the inverter on flammable construction materials.
- Mount on a solid surface
- Install this inverter at eye level in order to allow the LCD display to be read at all times.
- The ambient temperature should be between 0°C and 55°C to ensure optimal operation.
- The recommended installation position is to be adhered to the wall vertically.
- Be sure to keep other objects and surfaces as shown in the right diagram to guarantee sufficient heat dissipation and to have enough space for removing wires.

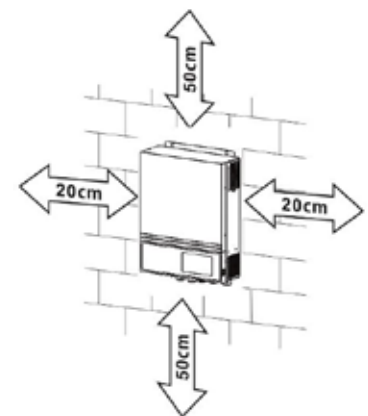

⚠️ SUITABLE FOR MOUNTING ON CONCRETE OR OTHER NON-COMBUSTIBLE SURFACE ONLY.

Install the unit by screwing three screws. It's recommended to use M4 or M5 screws.

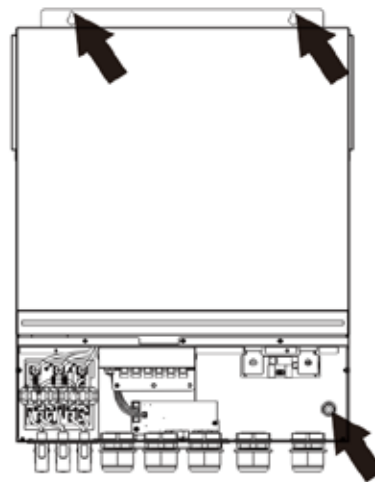

Battery Connection

CAUTION: For safety operation and regulation compliance, it's requested to install a separate DC over-current protector or disconnect device between battery and inverter. It may not be requested to have a disconnect device in some applications, however, it's still requested to have over-current protection installed. Please refer to typical amperage in below table as required fuse or breaker size.

WARNING! All wiring must be performed by a qualified personnel.

WARNING! It's very important for system safety and efficient operation to use appropriate cable for battery connection. To reduce risk of injury, please use the proper recommended cable and terminal size as below.

Ring terminal:

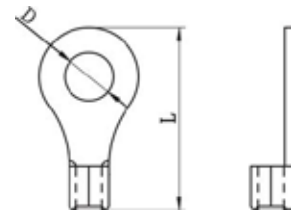



Recommended battery cable and terminal size:

| Model | Typical Amperage | Battery capacity | Wire Size | Cable mm ² | Ring Terminal Dimensions | | Torque value |
|-------|------------------|------------------|-----------|-----------------------|--------------------------|--------|--------------|
| | | | | | D (mm) | L (mm) | |
| 12KW | 242A | 250AH | 1*3/0AWG | 85 | 8.4 | 54 | 5 Nm |

Please follow below steps to implement battery connection:

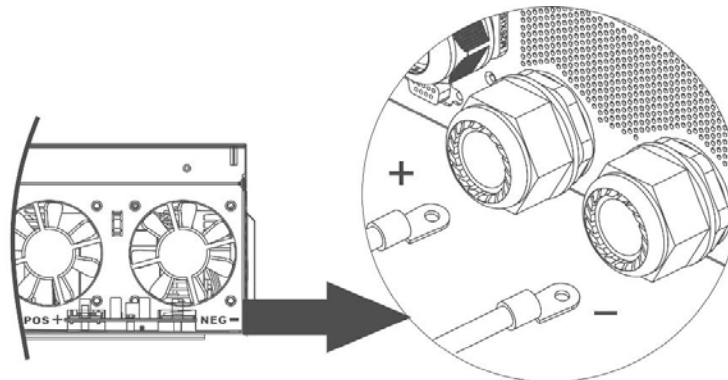
1. Assemble battery ring terminal based on recommended battery cable and terminal size.
2. Fix two cable glands into positive and negative terminals.
3. Insert the ring terminal of battery cable flatly into battery connector of inverter and make sure the nuts are tightened with torque of 5 Nm. Make sure polarity at both the battery and the inverter/charge is correctly connected and ring terminals are tightly screwed to the battery terminals.



 **WARNING: Shock Hazard**
Installation must be performed with care due to high battery voltage in series.

 **CAUTION!!** Do not place anything between the flat part of the inverter terminal and the ring terminal. Otherwise, overheating may occur.
CAUTION!! Do not apply anti-oxidant substance on the terminals before terminals are connected tightly.
CAUTION!! Before making the final DC connection or closing DC breaker/disconnector, be sure positive (+) must be connected to positive (+) and negative (-) must be connected to negative (-).

AC Input/Output Connection

CAUTION!! Before connecting to AC input power source, please install a **separate** AC breaker between inverter and AC input power source. This will ensure the inverter can be securely disconnected during maintenance and fully protected from over current of AC input.

CAUTION!! There are two terminal blocks with "IN" and "OUT" markings. Please do NOT mis-connect input and output connectors.

WARNING! All wiring must be performed by a qualified personnel.

WARNING! It's very important for system safety and efficient operation to use appropriate cable for AC input connection. To reduce risk of injury, please use the proper recommended cable size as below.

Suggested cable requirement for AC wires

| Model | Gauge | Torque Value |
|-------|-------|--------------|
| 12KW | 6 AWG | 1.4~ 1.6Nm |

Please follow below steps to implement AC input/output connection:

1. Before making AC input/output connection, be sure to open DC protector or disconnecter first.
2. Remove insulation sleeve 10mm for six conductors. And shorten phase L and neutral conductor N 3 mm.
3. Fix two cable glands into input and output sides.
4. Insert AC input wires according to polarities indicated on terminal block and tighten the terminal screws.

Be sure to connect PE protective conductor (⊕) first.

⊕ → **Ground (yellow-green)**
L → **LINE (brown or black)**
N → **Neutral (blue)**

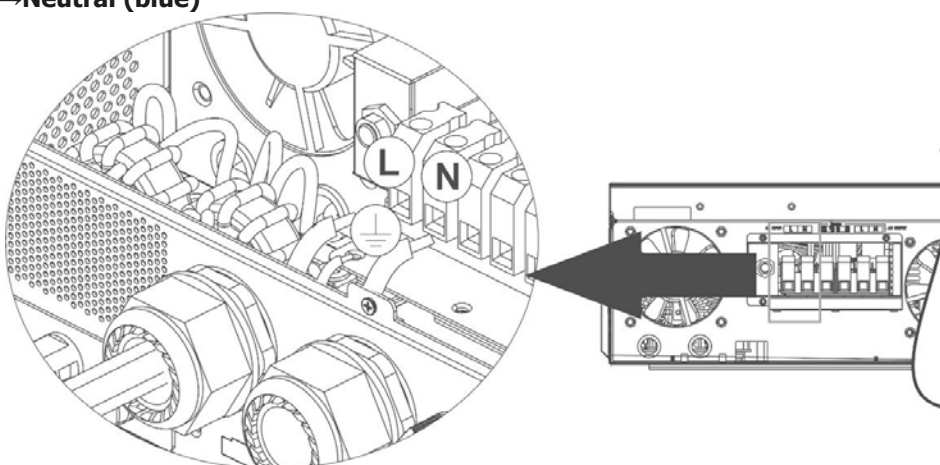

 **WARNING:**
Be sure that AC power source is disconnected before attempting to hardwire it to the unit.

5. This inverter is equipped with dual-output. There are four terminals (L1/N1, L2/N2) available on output port. It is to set up through LCD program or monitoring software to turn on and off the second output. Refer to "LCD setting" section for the details.
 Before making wiring of second output, please remove knockout and install the cable gland first. Insert AC output wires according to polarities indicated on terminal block and tighten terminal screws. Be sure to connect PE protective conductor (⊕) first.

- ⊕→**Ground (yellow-green)**
- L1**→**LINE (brown or black)**
- N1**→**Neutral (blue)**
- L2**→**LINE (brown or black)**
- N2**→**Neutral (blue)**

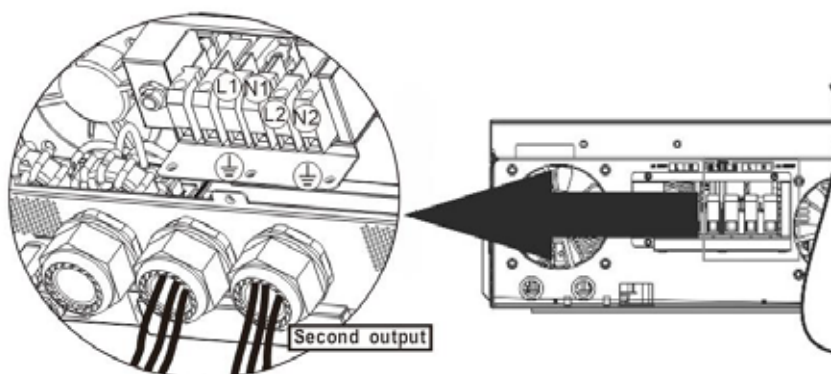

6. Make sure the wires are securely connected.

CAUTION: Important

Be sure to connect AC wires with correct polarity. If L and N wires are connected reversely, it may cause utility short-circuited when these inverters are worked in parallel operation.

CAUTION: Appliances such as air conditioner requires at least 2~3 minutes to restart because it's required to have enough time to balance refrigerant gas inside of circuits. If a power shortage occurs and recovers in a short time, it will cause damage to your connected appliances. To prevent this kind of damage, please check manufacturer of air conditioner if it's equipped with time-delay function before installation. Otherwise, this inverter/charger will be trigger overload fault and cut off output to protect your appliance but sometimes it still causes internal damage to the air conditioner.

PV Connection

CAUTION: Before connecting to PV modules, please install **separately** DC circuit breakers between inverter and PV modules.

NOTE1: Please use 600VDC/50A circuit breaker on each string.

NOTE2: The overvoltage category of the PV input is II.

Please follow the steps below to implement PV module connection:

WARNING: Because this inverter is non-isolated, only three types of PV modules are acceptable: single crystalline and poly crystalline with class A-rated and CIGS modules.

To avoid any malfunction, do not connect any PV modules with possible current leakage to the inverter. For example, grounded PV modules will cause current leakage to the inverter. When using CIGS modules, please be sure NO grounding.

CAUTION: It's required to use PV junction box with surge protection. Otherwise, it will cause damage on inverter when lightning occurs on PV modules.

Step 1: Check the input voltage of PV array modules. This system is applied with two strings of PV array. Please make sure that the maximum current load of each PV input connector is 40A.

CAUTION: Exceeding the maximum input voltage can destroy the unit!! Check the system before wire connection.

Step 2: Disconnect the circuit breaker and switch off the DC switch.

Step 3: Assemble provided PV connectors with PV modules by the following steps.

Components for PV connectors and Tools:

| | |
|---------------------------|--|
| Female connector housing | |
| Female terminal | |
| Male connector housing | |
| Male terminal | |
| Crimping tool and spanner | |

Prepare the cable and follow the connector assembly process:

Strip one cable 8 mm on both end sides and be careful NOT to nick conductors.

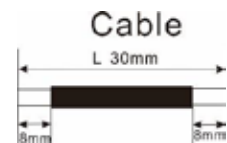

Insert striped cable into female terminal and crimp female terminal as shown below.



Insert assembled cable into female connector housing as shown below.



Insert striped cable into male terminal and crimp male terminal as shown below.



Insert assembled cable into male connector housing as shown below.



Then, use spanner to screw pressure dome tightly to female connector and male connector as shown below.



Step 4: Check correct polarity of connection cable from PV modules and PV input connectors. Then, connect positive pole (+) of connection cable to positive pole (+) of PV input connector. Connect negative pole (-) of connection cable to negative pole (-) of PV input connector.

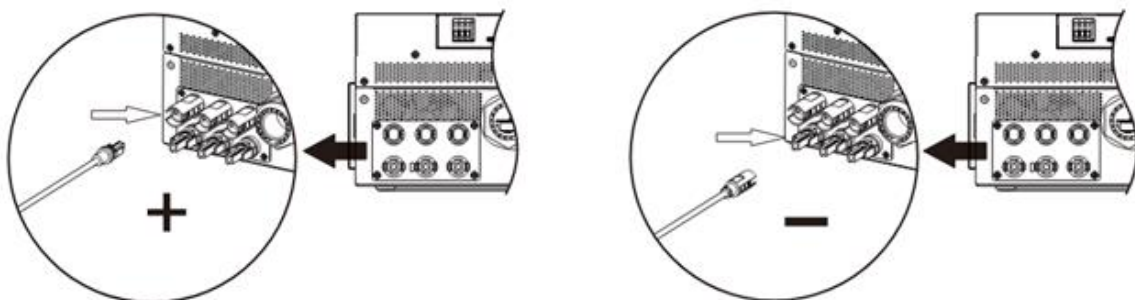

WARNING! For safety and efficiency, it's very important to use appropriate cables for PV module connection. To reduce risk of injury, please use the proper cable size as recommended below.

| | |
|--------------------------------------------|---------|
| Conductor cross-section (mm ²) | AWG no. |
| 6 | 10 |

CAUTION: Never directly touch the terminals of inverter. It might cause lethal electric shock.

Recommended Panel Configuration

When selecting proper PV modules, please be sure to consider the following parameters:

1. Open circuit Voltage (Voc) of PV modules not to exceed maximum PV array open circuit voltage of the inverter.
2. Open circuit Voltage (Voc) of PV modules should be higher than the start-up voltage.

| | |
|-----------------------------------------------|---------------|
| 3. INVERTER MODEL | 12KW |
| Max. PV Array Power | 18000W |
| Max. PV Array Open Circuit Voltage | 500Vdc |
| PV Array MPPT Voltage Range | 90Vdc~450Vdc |
| Max. Array Current of PV1 | 27A |
| Max. Array Current of PV2-1, PV2-2 | 27A, 27A |
| Max. Total Array Current (PV2-1+PV2-2) | 40A |
| Max. Total Array Current (PV1+PV2) | (20A+40A) 60A |
| Start-up Voltage (Voc) | 80Vdc |

Take the 555Wp PV module as an example. After considering above two parameters, the recommended module configurations are listed in the table below.

| Solar Panel Spec. (reference) | SOLAR INPUT 1 | SOLAR INPUT 2 | Q'ty of panels | Total Input Power |
|----------------------------------|------------------------------------------------------------------------------|----------------------------------------------------------------------------------|----------------|-------------------|
| | - 555Wp - Imp: 17.32A - Voc: 38.46Vdc - Isc: 18.33A - Cells: 110 | Min in series: 3pcs, per input Max. in series: 12pcs, per input | | |
| | 3pcs in series | x | 3pcs | 1665W |
| | x | 3pcs in series | 3pcs | 1665W |
| | 7pcs in series | x | 7pcs | 3885W |
| | x | 7pcs in series | 7pcs | 3885W |
| | 7pcs in series | 7pcs in series | 14pcs | 7770W |
| | 8pcs in series | 8pcs in series | 16pcs | 8880W |
| | 10pcs in series | 10pcs in series | 20pcs | 11100W |
| | 11pcs in series | 11pcs in series | 22pcs | 12210W |
| | 12pcs in series | 12pcs in series | 24pcs | 13320W |
| | 10pcs in series | 10pcs in series, 2 strings | 30pcs | 16650W |
| | 11pcs in series | 11pcs in series, 2 strings | 33pcs | 18315W |

Take the 720Wp PV module as an example. After considering above two parameters, the recommended module configurations are listed in the table below.

| Solar Panel Spec. (reference) - 720Wp - Vmp: 40.5Vdc - Imp: 17.44A - Voc: 49.4Vdc - Isc: 18.49A | SOLAR INPUT 1 | SOLAR INPUT 2 | Q'ty of panels | Total Input Power |
|-------------------------------------------------------------------------------------------------------------------|--------------------------------------------------------------------|---------------|----------------|-------------------|
| | Min in series: 3pcs, per input Max. in series: 10pcs, per input | | | |
| | 3pcs in series | x | 3pcs | 2160W |
| x | 3pcs in series | 3pcs | 2160W | |
| 10pcs in series | x | 10pcs | 7200W | |
| x | 10pcs in series | 10pcs | 7200W | |
| 8pcs in series | 8pcs in series | 16pcs | 11520W | |
| 9pcs in series | 9pcs in series | 18pcs | 12960W | |
| 10pcs in series | 10pcs in series | 20pcs | 14400W | |
| 7pcs in series, 2 strings | 7pcs in series | 21pcs | 15120W | |
| 8pcs in series, 2 strings | 8pcs in series | 24pcs | 17280W | |

Final Assembly

After connecting all wirings, re-connect three cables and then put bottom cover back by screwing five screws as shown below.

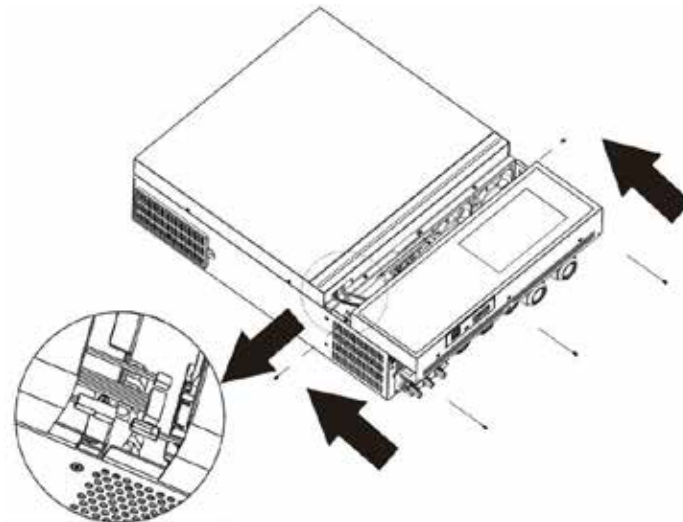

Communication Connection

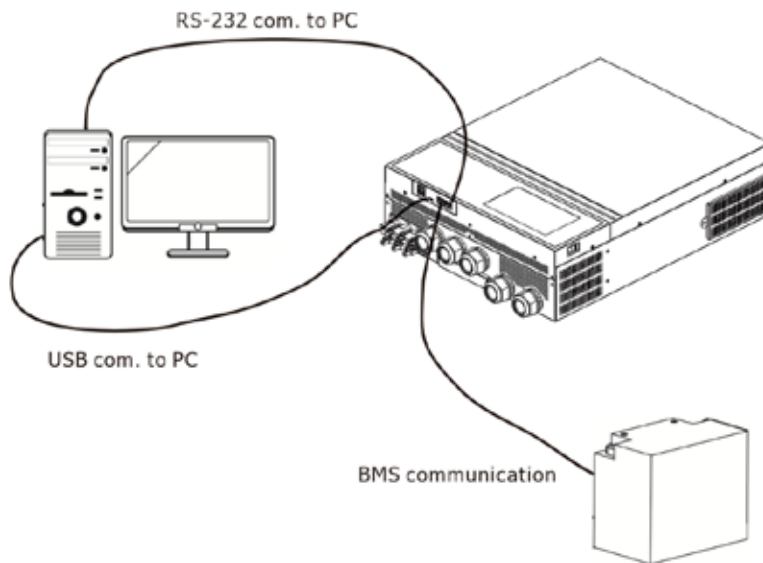

Serial Connection

Please use the supplied serial cable to connect between the inverter and your PC. Install the monitoring software from the bundled CD and follow the on-screen instructions to complete your installation. For detailed software operation, refer to the software user manual on the bundled CD.

Pin assignment

| PIN # | Definition | PIN # | Definition |
|-------|-------------------|-------|------------|
| PIN 1 | TXD from Inverter | PIN 5 | X |
| PIN 2 | RXD to Inverter | PIN 6 | X |
| PIN 3 | X | PIN 7 | X |
| PIN 4 | X | PIN 8 | GND |

Serial Connection: BMS port

Pin assignment

| PIN # | Definition | PIN # | Definition |
|-------|------------|-------|------------|
| PIN 1 | X | PIN 5 | RS485P |
| PIN 2 | X | PIN 6 | CANH |
| PIN 3 | RS485N | PIN 7 | CANL |
| PIN 4 | X | PIN 8 | GND |

USB port (Type C)

Pin assignment

| PIN # | Definition | PIN # | Definition |
|-----------|------------|----------|------------|
| PIN 1, 12 | GND | PIN 5, 7 | D- |
| PIN 2, 11 | VBUS | PIN 6, 8 | D+ |
| PIN 3 | X | PIN 9 | X |
| PIN 4 | CC1 | PIN 10 | CC2 |

DRY-Contact port

| Unit Status | Condition | | |  NC & C NO & C | |
|-------------|-------------------------------------------------------|-----------------------------------------------------|---------------------------------------------------------------------------------------------------------------------------------------|---------------------------------------------------------------------------------------------------------|--------|
| | | | | NC & C | NO & C |
| Power Off | Unit is off and no output is powered. | | | Close | Open |
| Power On | Output is powered from Battery power or Solar energy. | Output source priority set as USB (utility first) | Battery voltage < Low DC warning voltage | Open | Close |
| | | | Battery voltage > Setting value in Re-Discharging Voltage/SOC point when grid is available or battery charging reaches floating stage | Close | Open |
| | | Output source priority is set as SBU (SBU priority) | Battery voltage < Setting value in Stop Discharge Voltage/SOC point when grid is available | Open | Close |
| | | | Battery voltage > Setting value in Re-Discharging Voltage/SOC point when grid is available or battery charging reaches floating stage | Close | Open |

Wi-Fi Connection

Users can remotely monitor and control their inverters when they combine the Wi-Fi module with Energy-Mate APP. The App uses the Wi-Fi chip to provide remote monitoring data services, which is beneficial for the daily data monitoring of the inverter, querying the real-time data in the device, sending commands from the device, and operating the device remotely. The app is available for both iOS and Android.

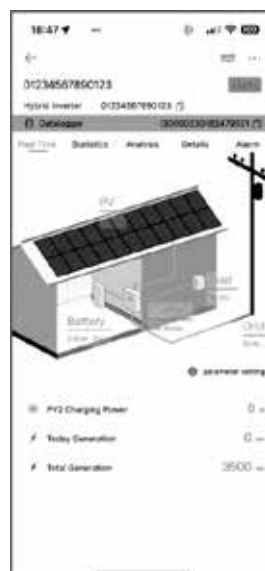

OPERATION

Power ON/OFF

Once the unit has been properly installed and the batteries are connected well, simply press On/Off switch to turn on the unit.



Inverter Turn-on

After this inverter is turned on, WELCOME light show will be started with RGB LED BAR. It will slowly cycle through entire spectrum of nine colors (Green, Sky blue, Royal blue, Violet, Pink, Red, Honey, Yellow, Lime yellow) about 10-15 seconds. After initialization, it will light up with default color.

RGB LED BAR can light up in different color and light effects based on the setting of energy priority to display the operation mode, energy source, battery capacity and load level. These parameters such as color, effects, brightness, speed and so on can be configured through the LCD panel. Please refer to LCD settings for the details.

Operation and Display Panel

The operation and the LCD module, shown in the chart below, includes one power switch and a HMI LCD display to indicate the operating status and input/output power information.

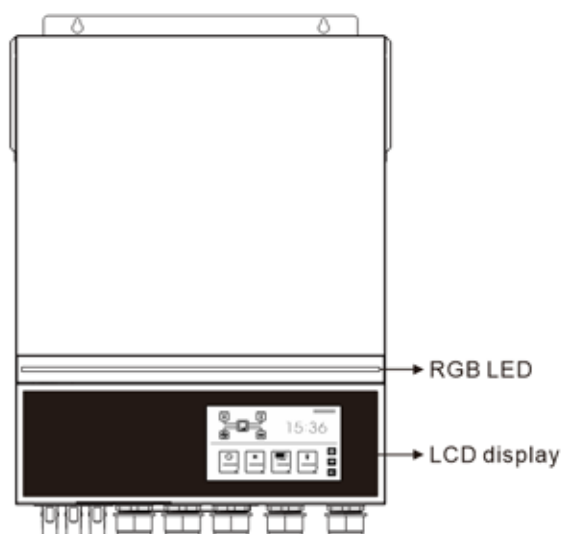

Human Interface Specification

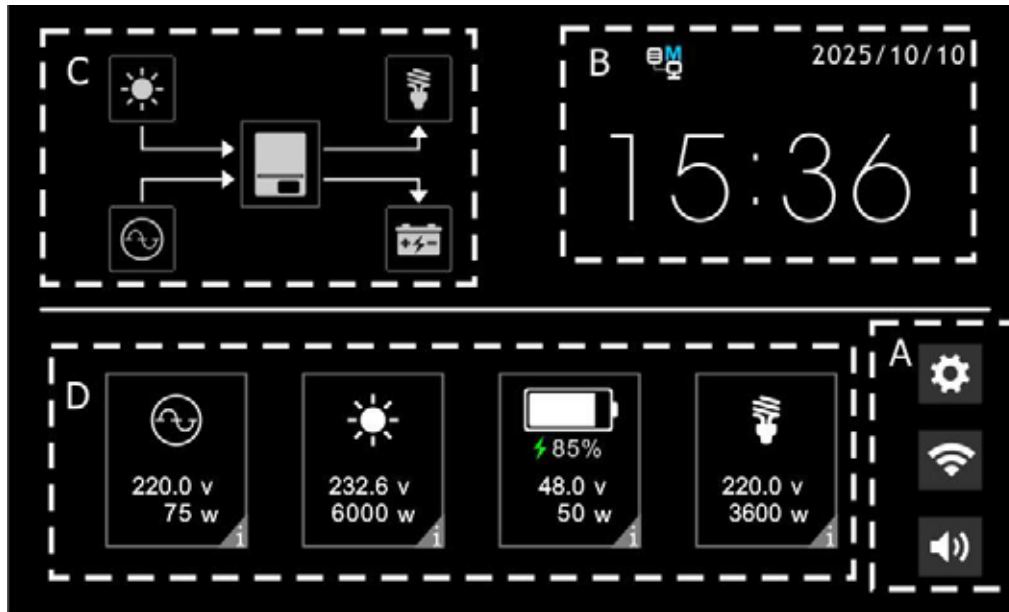

A: It displays WiFi and buzzer status. You also can access setting programs by clicking  icon.

B: It indicates date/time and parallel status (Single/Master/Slave/L1, L2, L3 Phase).

C: It displays direction of energy flow with arrows to indicate the working status of the inverter.

D: It shows information including solar info, grid info, battery info, load info and warning/fault codes.

● Main Page

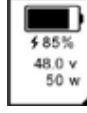
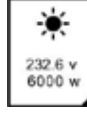
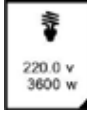
| | | |
|--|-------------------------------------------------------------------------------------------------------------------------------------------------|-----------------------------------------------------------------------------------------------------------------------------------------------------------------------------------------------------------------------------------------------------------------------------------------------|
| | <p>Touch the following any button to browse individual energy bar charts.</p> | |
| | <p>Touch  to browse daily AC input energy in bar charts.</p> | |
| | | <p>Touch  to browse daily battery charging energy in bar charts. Touch the icon again to switch to battery discharging energy in bar charts.</p> |
| | | <p>Touch  to browse daily solar energy in bar charts and touch  to browse daily load consumption in bar charts.</p> |

● **Grid Info Page**

Press the right bottom "i" of icon to access Grid Info page.

This page lists Grid information including:

- Grid frequency
- Input Voltage
- Input Current
- Grid consumption by today, this month, this year and total amount.
- Power flow state: Buy energy
- Grid power value

Press "Energy Chart" to browse detail grid energy in bar charts.

Press HOME icon to return to main page.

Grid in energy chart

It lists daily, monthly, yearly and total Grid in power in bar charts.

Press HOME icon to return to main page.

Press "ESC" icon back to previous page.

● **Solar Info Page**

🏠 Solar

| | | |
|---------------------|-------|---|
| Total Solar Power : | 5754 | W |
| PV1 Input Voltage : | 230.1 | V |
| PV1 Input Current : | 15 | A |
| PV1 Input Power : | 3452 | W |
| PV2 Input Voltage : | 230.2 | V |
| PV2 Input Current : | 10 | A |
| PV2 Input Power : | 2302 | W |

| | | | |
|-------------|----------|--------------|----------|
| Today = | 0.9 KWH | This Month = | 12.6 KWH |
| This Year = | 20.3 KWH | Total = | 51.8 KWH |

(Energy Chart)

Press the right bottom "i" of  icon to access Solar Info page.

This page lists solar information including:

- Total solar power
- PV1 input voltage, PV1 input current, PV1 input power
- PV2 input voltage, PV2 input current, PV2 input power
- Solar energy generation in daily, monthly, yearly and total amount

Press "Energy Chart" to browse detail solar power in bar charts.

Press HOME icon to return to main screen.

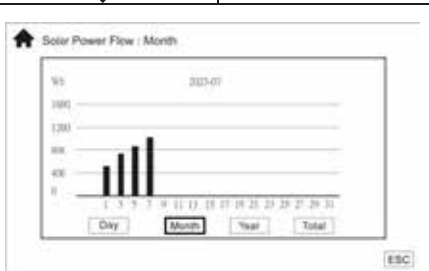
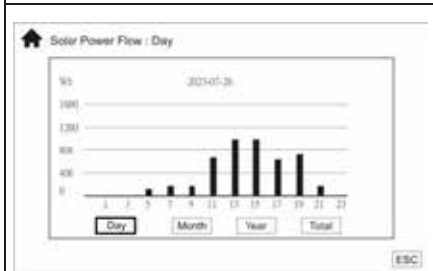

It lists daily, monthly, yearly and total solar power generation in bar charts.

Press HOME icon to return to main page.

Press "ESC" icon back to previous page.

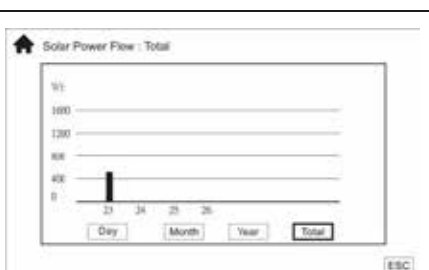
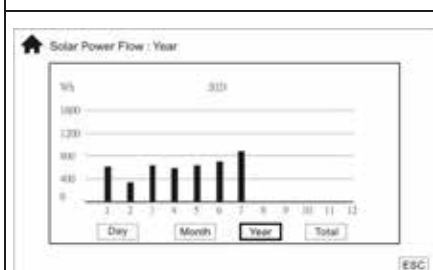

● **Battery Info Page**

Battery

| | | | |
|--------------------------|----------|-------------------|----------|
| Battery Type : | USE | Battery Voltage : | 48.0 V |
| Status : | | Battery Current : | 15 A |
| SOC : | 85 % | Power : | 720 W |
| Battery Charge | | | |
| Today = | 0.9 KWH | This Month = | 12.6 KWH |
| This Year = | 20.3 KWH | Total = | 51.8 KWH |
| Battery Discharge | | | |
| Today = | 0.9 KWH | This Month = | 12.6 KWH |
| This Year = | 20.3 KWH | Total = | 51.8 KWH |

BMS Information Energy Chart

Press the right bottom "i" of  icon to access Battery Info page.

It lists battery information including:

- Battery Type
- Battery status
- SOC percentage
- Battery voltage
- Battery current
- Battery power
- Battery charged with kWh daily, monthly, yearly and total amount.
- Battery discharged with kWh daily, monthly, yearly and total amount.

If it shows negative value, it means discharging status. If it shows positive value, it means charging status. It also shows battery energy generation by today, this month, this year, and total amount since installation.

If lithium battery is used, access battery information by touching "BMS Information".

Press "Energy Chart" to browse battery data in bar charts.

Press HOME icon to return to main page.

BMS Information

Communication State :

Max Charging Voltage :

Max Charging Current :

Cut-off Voltage :

Max Discharging Current :

ESC

BMS Information

It lists the BMS information including:

- BMS communication status
- Max. charging voltage
- Max. charging current
- Cut-off voltage
- Max. discharging current.

Press ESC icon to return to previous page.

Battery Power Flow

Charge Discharge

ESC

Battery Power Flow

Charge Discharge

ESC

Press "Energy Chart" to access **battery charging and discharging data** in bar charts.

It lists daily, monthly, yearly and total battery charge and discharge power in bar charts.

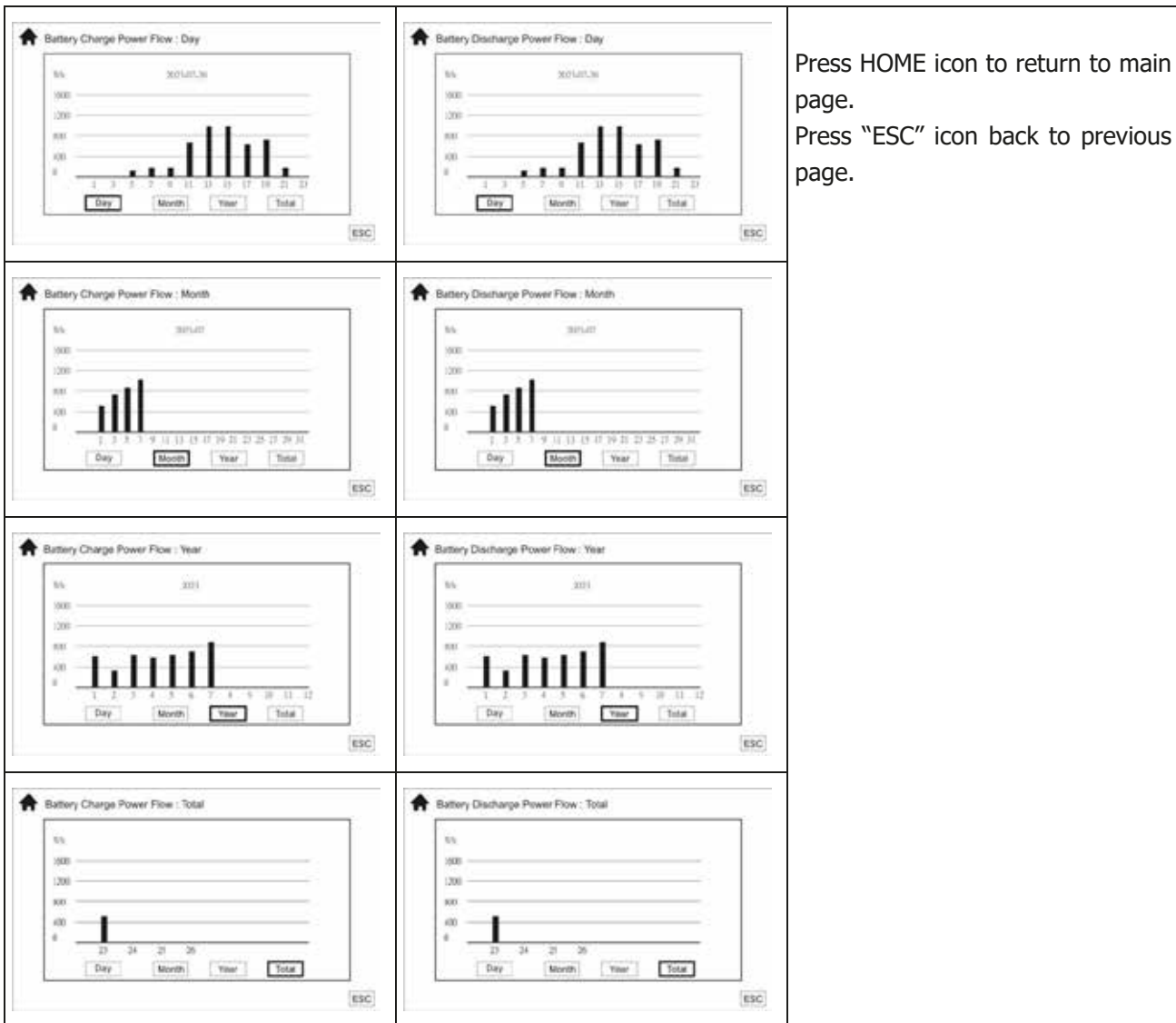



Press HOME icon to return to main page.
Press "ESC" icon back to previous page.

● **Load Info Page**

| | | |
|---------------------------------------------------------------------------------------------------------------------------------------------------------------------------------------------------------------------------------------------------------------------------------------------------------------------------------------------------------------------------------------------------------------------------------------------------------------------------------------------------------------------------|----------------------------------------------------------------------------------------------------------------------------------------------------------------------------------------------------------------------------------------------------------------------------------------------------------------------------------------------------------------------------------------------------------------|----------------------------------------------------------------------------------------------------|
| <p> Load </p> <div style="border: 1px solid black; padding: 5px;"> <p> Output Frequency : 60 HZ Output1 Voltage : 232.6 V Output2 Voltage : 232.6 V Output Power : 900 W Output Power Percent : 40 % </p> <p> Today = 0.9 KWH This Month = 12.6 KWH This Year = 20.3 KWH Total = 51.8 KWH </p> </div> <p style="text-align: center; border: 1px dashed black; padding: 2px;">Energy Chart</p> | <p style="text-align: right;"> 220.0 v 3600 </p> <p>Press the right bottom "i" of icon to access Load Info page.</p> <p>It lists the output frequency, output1/output2 voltage, output power, output power percent, energy generated today, this month, this year and totally.</p> <p>Press "Energy Chart" to browse load data in bar charts.</p> <p>Press HOME icon to return to main page.</p> | |
| <p> Load Power Flow : Day</p> <p style="text-align: right;">ESC</p> | <p> Load Power Flow : Month</p> <p style="text-align: right;">ESC</p> | <p>It lists daily, monthly, yearly and total battery charge and discharge power in bar charts.</p> |
| <p> Load Power Flow : Year</p> <p style="text-align: right;">ESC</p> | <p> Load Power Flow : Total</p> <p style="text-align: right;">ESC</p> | <p>Press HOME icon to return to main page.</p> <p>Press "ESC" icon back to previous page.</p> |

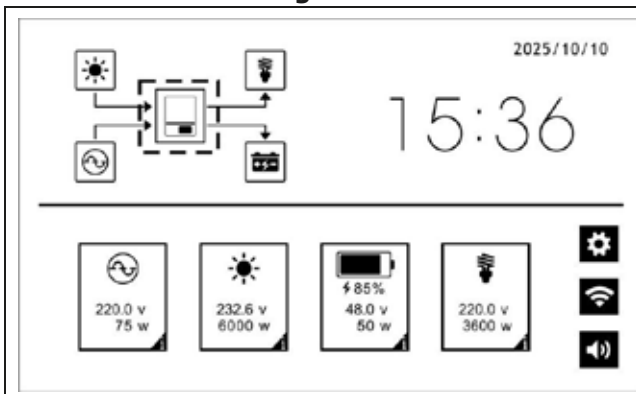
● **Inverter Info Page**



Press inverter icon  in power flow chart to access inverter info page.

It lists inverter detailed information including:

- Serial number
- Parallel status
- System work mode
- DSP version
- MCU1 version
- LCD version of the inverter



Press HOME icon to return to main screen.

Press "Event" show Event log page.

Press "ESC" icon back to previous page.

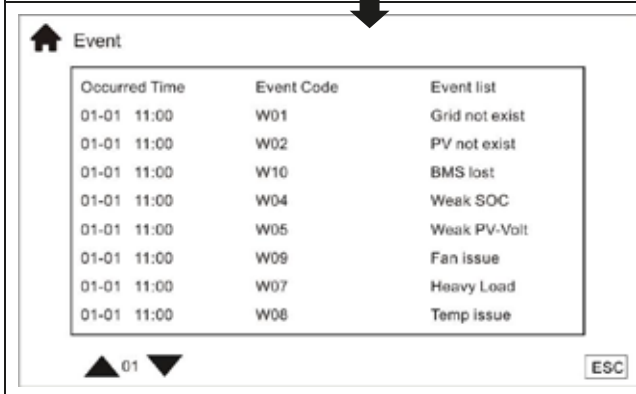

Event log page

It lists the time, event code and description of the event.

Press HOME icon to return to main page.

Press "ESC" icon back to previous page.

System Setting

Press to access system setting menu.

The system setting includes:

- General Setting
- Battery Setting
- Grid Setting
- Output Setting
- Advanced Setting

● System Setting- General Setting

Time Setting: Set system time

LCD Sleep Time: 3 minute, 5 minute, Disable

Alarm control: Enable, Disable

Data log Storage Period: 1~6 week

Fault Auto-Restart: Enable, Disable

Overload Bypass: Enable, Disable

NOTE: The values shown in the picture are default values.

| | |
|---------------------------------------------------------------------------------------------------------------------------------------------------------------------------------------------------------------------------------------------------------------------------------------|-------------------------------------------------------------------------------------------------------------------------------------------------------------------------------------------------------------------------------------------------------------------------------------------------------------------------------------------------------------------------------------------------------------------------------------------------------------------------------------------|
| <p>General Setting</p> <ul style="list-style-type: none"> LED Enable : Enable LED Brightness : Normal LED Speed : Normal LED Effect : Breathing LED Mode : Energy Source LED Color : Violet-White-Sky blue <p>▲ ▼ ESC</p> | <p>LED Enable: Enable, Disable</p> <p>LED Brightness: Low, Normal, High</p> <p>LED Speed: Low, Normal, High</p> <p>LED Effect: Scrolling, Breathing, Solid On</p> <p>LED Mode: Energy Source, Battery Status</p> <p>LED Color: Energy Source: Violet-White-Sky, White-Yellow-Green Battery Status: Pink-Honey, Royal-Blue lime-Yellow</p> <p>NOTE: The values shown in the picture are default values.</p> |
|---------------------------------------------------------------------------------------------------------------------------------------------------------------------------------------------------------------------------------------------------------------------------------------|-------------------------------------------------------------------------------------------------------------------------------------------------------------------------------------------------------------------------------------------------------------------------------------------------------------------------------------------------------------------------------------------------------------------------------------------------------------------------------------------|

● **System Setting- Battery Setting**

| | |
|---------------------------------------------------------------------------------------------------------------------------------------------------------------------------------------------------------------------------------------------------------------------------------------------------------------------------------------------------------------------------------------------------|------------------------------------------------------------------------------------------------------------------------------------------------------------------------------------------------------------------------------------------------------------------------------------------------------------------------------------------------------------------------------------------------------------------------------------------------------------------------------------------------------------------------------------------------------------------------------------------------------------------------------------------------------------------------------------------|
| <p>System Setting</p> <ul style="list-style-type: none"> General Setting Battery Setting Output Setting Advanced Setting Grid Setting | <p>Battery Type: AGM, Flooded, User Defined, BYD, Pylon, Weco, Soltaro, LIA, LIB, LIC</p> <p>Charger Source Priority: Solar, Solar and Utility, Solar Only</p> <p>Max. (Grid+Solar) Charging Current: 10A, 20A~200A</p> <p>Max. Utility Charging Current: 2A, 10A, 20A~200A</p> <p>Max. Discharging Current: Disabled, 30A ~200A</p> <p>Bulk Charging Voltage(CV): 48.0, 48.1, 48.2~62.0V</p> <p>Floating Charging Voltage: 48.0, 48.1, 48.2~62.0V</p> <p>NOTE: The values shown in the picture are default values.</p> |
| <p>Battery Setting</p> <ul style="list-style-type: none"> Battery Type : AGM Charging Source Priority : Solar and Utility Max. (Grid+Solar) Charging Current : 60A Max. Utility Charging Current : 30A Max. Discharging Current : Disable Bulk Charging Voltage(CV) : 56.4V Floating Charging Voltage : 54.0V <p>▲ ▼ ESC</p> | |

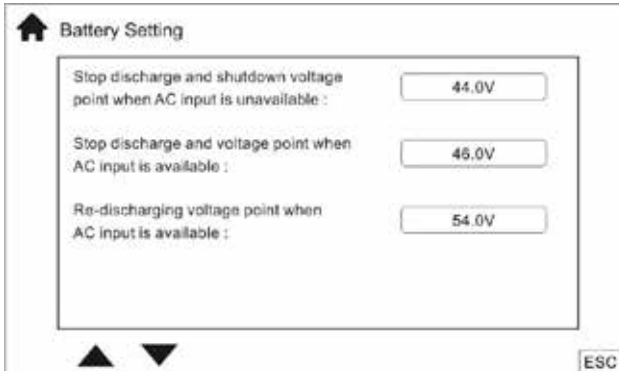
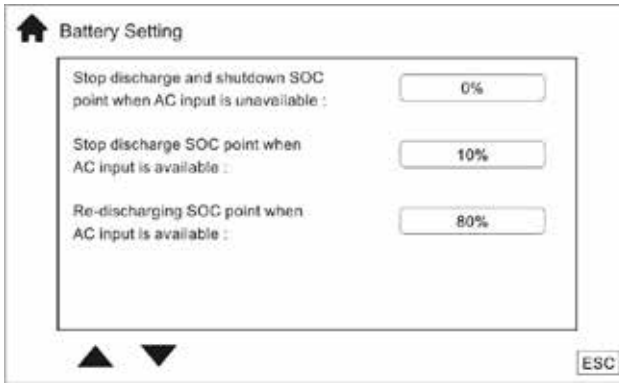
| | |
|----------------------------------------------------------------------------------------------------------------|--------------------------------------------------------------------------------------------------------------------------------------------------------------------------------------------------------------------------------------------------------------------------------------------------------------------------------------------------------------------------------------------------------------------------------------------|
| <p>Voltage screen</p>  | <p>Stop discharge and shutdown voltage/SOC point when AC input is unavailable: Voltage: 42~48V SOC : 0~90%</p> <p>Stop discharge voltage/SOC point when AC input is available: Voltage: 44~56V SOC: 5~95%</p> <p>Re-discharging Voltage/SOC point when AC input is available: Voltage: Fully, 48~62V SOC: 10~100%</p> <p>NOTE: The values shown in the picture are default values.</p> |
| <p>SOC screen</p>  | <p>Equalization Function: Enable, Disable Equalization Voltage: 48.0, 48.1, 48.2~62.0V Equalization Interval: 0, 1, 2~90days Equalization Time: 5, 10, 15~900min Equalization Timeout: 5, 10, 15~900min Equalization Immediately: Enable, Disable</p> <p>NOTE: The values shown in the picture are default values.</p> |

● **System Setting- Grid Setting**

| | |
|-------------------------------------------------------------------------------------------------------------------------------------------------------------------------------------------------------------------------------------------------------|-----------------------------------------------------------------------------------------------------------------------------------------------------------------------------------------------------------------------------------------------------------------------|
| <p>System Setting</p> <ul style="list-style-type: none"> General Setting Output Setting Battery Setting Advanced Setting Grid Setting | <p>AC Input Voltage Range: Utility, Generator, Generator-Sensitive</p> <p>Earth LED Calibration: -30, -29, -28~30</p> <p>Reverse LED Calibration: 0, 10, 20~300W</p> <p>NOTE: The values shown in the picture are default values.</p> |
| <p>Grid Setting</p> <p>AC Input Voltage Range : <input type="text" value="Generator"/></p> <p>Earth LED Calibration : <input type="text" value="Condition 10 0"/></p> <p>Reverse LED Calibration(W) : <input type="text" value="200"/></p> <p>ESC</p> | |

● **System Setting- Output Setting**

| | |
|-------------------------------------------------------------------------------------------------------------------------------------------------------------------------------------------------|--|
| <p>System Setting</p> <ul style="list-style-type: none"> General Setting Output Setting Battery Setting Advanced Setting Grid Setting | |
|-------------------------------------------------------------------------------------------------------------------------------------------------------------------------------------------------|--|

Voltage screen

Output Setting

| | |
|----------------------------|-------------|
| Output Voltage : | 230V |
| Output Frequency : | 50Hz |
| AC Output Mode : | Single |
| Output Source Priority : | USB |
| Discharge Voltage O/P-2 : | 42.0V |
| Discharge Time O/P-2 : | Disable |
| Discharge Interval O/P-2 : | 00.00-23.59 |

▲ ▼ ESC

Output Voltage: 220, 230, 240V

Output Frequency: 50, 60Hz

AC Output mode: Single, Parallel, L1 Phase, L2 Phase, L3 Phase

Output Source Priority: USB, SUB, SBU

Discharge voltage/SOC O/P-2:

Voltage: 42.0, 42.1, 42.2~60.0V

SOC: 0~95%

Discharge time O/P-2: Disabled, 0, 5, 10~990

Discharge interval O/P-2: 0~23

SOC screen

Output Setting

| | |
|----------------------------|-------------|
| Output Voltage : | 230V |
| Output Frequency : | 50Hz |
| AC Output Mode : | Single |
| Output Source Priority : | USB |
| Discharge SOC O/P-2 : | 0% |
| Discharge Time O/P-2 : | Disable |
| Discharge Interval O/P-2 : | 00.00-23.59 |

▲ ▼ ESC

NOTE: The values shown in the picture are default values.

Voltage screen

Output Setting

| | |
|------------------------------|-------|
| Re-Discharge Voltage O/P-2 : | 46.0V |
| Re-Discharge Time O/P-2 : | 0 |

▲ ▼ ESC

Re-Discharge voltage/SOC O/P-2:

Voltage: 42.0, 42.1, 42.2~60.0V

SOC: 0~95%

Re-Discharge time O/P-2: Disabled, 0, 5, 10~990

NOTE: The values shown in the picture are default values.

SOC screen

Output Setting

| | |
|---------------------------|-----|
| Re-Discharge SOC O/P-2 : | 20% |
| Re-Discharge Time O/P-2 : | 0 |

▲ ▼ ESC

● **System Setting- Advanced Setting**

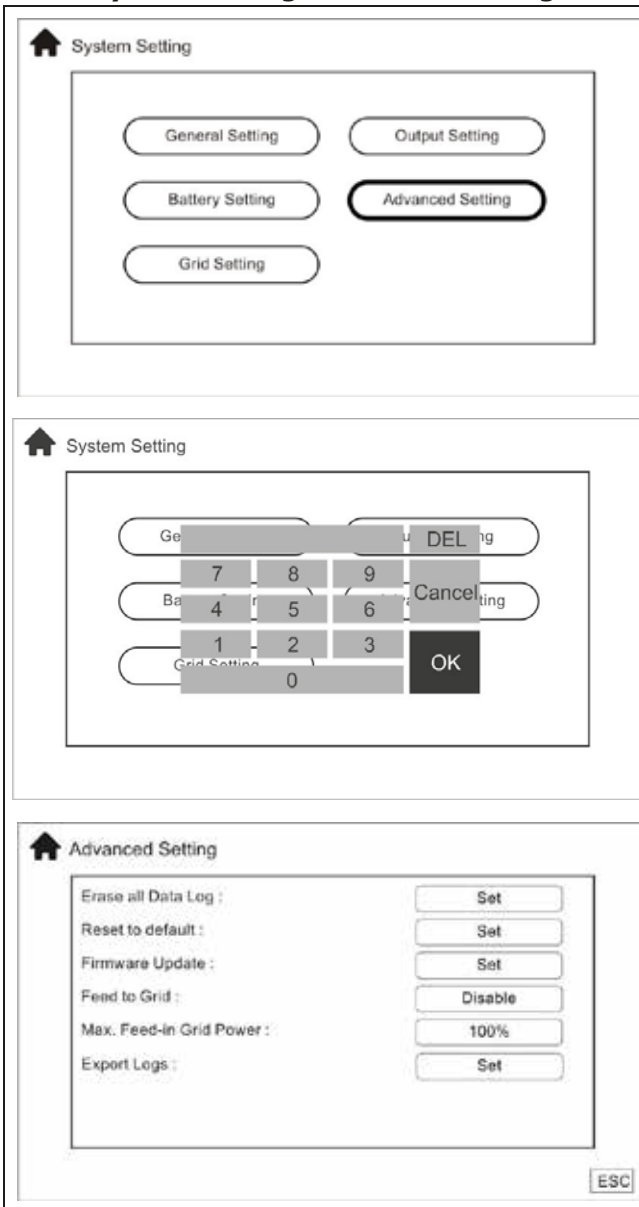

It's necessary to enter Password **4743** to access advanced setting.

- Erase all Data log:** OK, Cancel
- Reset to default:** OK, Cancel
- Firmware Update:** Panel, DSP
- Feed to Grid:** Enable, Disable
- Feed Power to Grid limitation:** 10, 20 ~ 100%
- Export Logs:** OK, Cancel

NOTE: The values shown in the picture are default values.

Warning and Fault List

| Code Type | Code # | Event | Code Type | Code # | Event |
|-----------|--------|-----------------|-----------|--------|------------------------|
| Fault | F01 | Fan fault | Fault | F16 | Inv start fault |
| Fault | F02 | High PV-volt | Fault | F17 | High dc offset |
| Fault | F03 | High bat-volt | Fault | F18 | Over-load |
| Fault | F04 | Low bat-volt | Fault | F19 | Amp sense fault |
| Fault | F05 | Output S.C. | Fault | F20 | Backfeed fault |
| Fault | F06 | High op-volt | Fault | F21 | Firmware fault |
| Fault | F07 | Low op-volt | Fault | F22 | Par-CAN fault |
| Fault | F08 | High bus-volt | Fault | F23 | Par-host fault |
| Fault | F09 | Low bus-volt | Fault | F24 | Par-sync fault |
| Fault | F10 | High PV-amp | Fault | F25 | Par-bat fault |
| Fault | F11 | High inv-amp | Fault | F26 | Par-grid fault |
| Fault | F12 | High bus-amp | Fault | F27 | Par-opa fault |
| Fault | F13 | High disc-amp | Fault | F28 | Par-set fault |
| Fault | F14 | Over temp. | Fault | F29 | OP Circuit Fault |
| Fault | F15 | Bus start fault | Fault | F33 | FW Different |
| Warning | W01 | Grid not exist | Warning | W11 | Comm. Lost |
| Warning | W02 | PV not exist | Warning | W12 | Par limited |
| Warning | W03 | Pack not exist | Warning | W13 | Ip CB trip |
| Warning | W04 | Weak SoC | Warning | W14 | EQ warning |
| Warning | W05 | Weak PV-volt | Warning | W15 | MCU comm. lost |
| Warning | W06 | Power de-rate | Warning | W16 | Disable CHG& DISCHG |
| Warning | W07 | Heavy load | Warning | W17 | Disable CHG |
| Warning | W08 | Temp issue | Warning | W18 | Disable DISCHG |
| Warning | W09 | Fan issue | Warning | W19 | Force CHG |
| Warning | W10 | BMS lost | | | |

BATTERY EQUALIZATION

Equalization function is added into charge controller. It reverses the buildup of negative chemical effects like stratification, a condition where acid concentration is greater at the bottom of the battery than at the top. Equalization also helps to remove sulfate crystals that might have built up on the plates. If left unchecked, this condition, called sulfation, will reduce the overall capacity of the battery. Therefore, it's recommended to equalize battery periodically.

● How to Apply Equalization Function

You must enable battery equalization function in monitoring LCD setting Equalization function first. Then, you may apply this function in device by either one of following methods:

1. Setting equalization interval in LCD
2. Active equalization immediately in LCD

● When to Equalize

In float stage, when the setting equalization interval (battery equalization cycle) is arrived, or equalization is active immediately, the controller will start to enter Equalize stage.

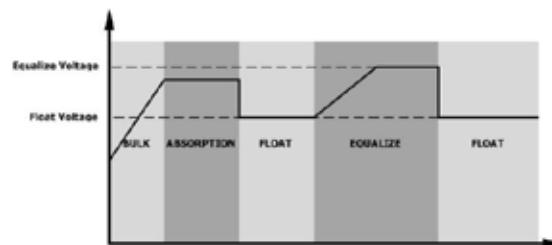

● Equalize charging time and timeout

In Equalize stage, the controller will supply power to charge battery as much as possible until battery voltage raises to battery equalization voltage. Then, constant-voltage regulation is applied to maintain battery voltage at the battery equalization voltage. The battery will remain in the Equalize stage until setting battery equalized time is arrived.

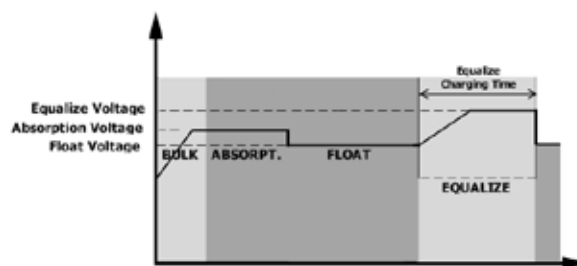

However, in Equalize stage, when battery equalized time is expired and battery voltage doesn't rise to battery equalization voltage point, the charge controller will extend the battery equalized time until battery voltage achieves battery equalization voltage. If battery voltage is still lower than battery equalization voltage when battery equalized timeout setting is over, the charge controller will stop equalization and return to float stage.

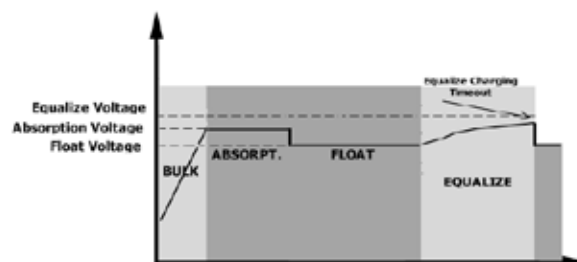

SPECIFICATIONS

Table 1 Line Mode Specifications

| MODEL | 12KW |
|-------------------------------------------------------------------------------------------------------|---------------------------------------------------------------------------------------------------------------------------------------------------------------------------------------------------------------------------------------------------------------------------------------------------------------------------------------------|
| Input Voltage Waveform | Sinusoidal (utility or generator) |
| Nominal Input Voltage | 230Vac |
| Low Loss Voltage | 170Vac±7V (UPS) 90Vac±7V (Appliances) |
| Low Loss Return Voltage | 180Vac±7V (UPS); 100Vac±7V (Appliances) |
| High Loss Voltage | 280Vac±7V |
| High Loss Return Voltage | 270Vac±7V |
| Max AC Input Voltage | 300Vac |
| Max AC Input Current | 60A |
| Max Output Current for 2nd output | 60A |
| Nominal Input Frequency | 50Hz / 60Hz (Auto detection) |
| Low Loss Frequency | 40±1Hz |
| Low Loss Return Frequency | 42±1Hz |
| High Loss Frequency | 65±1Hz |
| High Loss Return Frequency | 63±1Hz |
| Output Short Circuit Protection | Line mode: Circuit Breaker (70A) Battery mode: Electronic Circuits |
| Efficiency (Line Mode) | >95% (Rated R load, battery full charged) |
| Transfer Time | 10ms typical (UPS); 20ms typical (Appliances) |
| Output power de-rating: When AC input voltage under 170V the output power will be de-rated. | <p>The graph plots Output Power on the y-axis against Input Voltage on the x-axis. The x-axis has markers at 90V, 170V, and 280V. The y-axis has markers for 50% Power and Rated Power. The power curve starts at 90V with 50% power, rises linearly to reach Rated Power at 170V, and then remains constant at Rated Power until 280V.</p> |

Table 2 Inverter Mode Specifications

| MODEL | 12KW |
|------------------------------------------------------------------------------------------------------------------------------------------------------------------------------------------------------------------------------------------------------------------------------------------------------------------|----------------------------------------------------------------|
| Rated Output Power | 12000W |
| Output Voltage Waveform | Pure Sine Wave |
| Output Voltage Regulation | 230Vac±5% |
| Output Frequency | 60Hz or 50Hz |
| Peak Efficiency | 93% |
| Overload Protection | 100ms@≥180% load;5s@≥120% load; 10s@105%~120% load |
| Surge Capacity | 2* rated power for 5 seconds |
| Low DC Warning Voltage @ load < 20% @ 20% ≤ load < 50% @ load ≥ 50% | 46.0Vdc 42.8Vdc 40.4Vdc |
| Low DC Warning Return Voltage @ load < 20% @ 20% ≤ load < 50% @ load ≥ 50% | 48.0Vdc 44.8Vdc 42.4Vdc |
| Low DC Cut-off Voltage @ load < 20% @ 20% ≤ load < 50% @ load ≥ 50% | 44.0Vdc 40.8Vdc 38.4Vdc |
| High DC Recovery Voltage | 61Vdc |
| High DC Cut-off Voltage | 63Vdc |
| DC Voltage Accuracy | +/-0.3V@ no load |
| THDV | <5% for linear load,<10% for non-linear load @ nominal voltage |
| DC Offset | ≤100mV |
| Power Limitation When battery voltage is lower than 55Vdc, output power will be derated. If connected load is higher than this derated power, the AC output voltage will decrease until the output power reduces to this derated power. The minimum AC output voltage is output voltage setting – 10V. | |

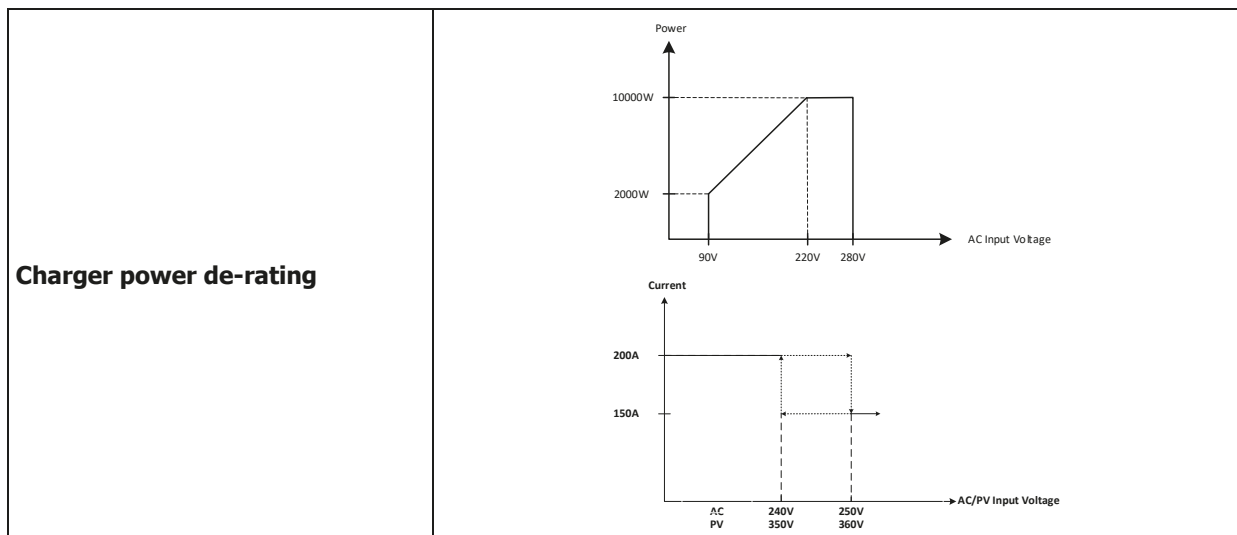

Table 3 Charge Mode Specifications

| Utility Charging Mode | | |
|----------------------------------------------------------|--------------------------|----------------------------------|
| MODEL | | 12KW |
| Charging Current (UPS) @ Nominal Input Voltage | | 200A |
| Bulk Charging Voltage | Flooded Battery | 58.4Vdc |
| | AGM / Gel Battery | 56.4Vdc |
| Floating Charging Voltage | | 54Vdc |
| Overcharge Protection | | 63Vdc |
| Charging Algorithm | | 3-Step |
| Charging Curve | | |
| Solar Input | | |
| MODEL | | 12KW |
| Rated Power | | 18000W (12000W max. per tracker) |
| Max. PV Array Open Circuit Voltage | | 500Vdc |
| PV Array MPPT Voltage Range | | 90Vdc~450Vdc |
| Number of MPP Trackers | | 2 |
| Number of Strings per MPP Tracker | | PV1: 1, PV2: 2 |
| Max. Input Current | | 27A/40A (MAX 60A) |

| | |
|------------------------------|--------------|
| Max. Charging Current | 200A |
| Start-up Voltage | 80V +/- 5Vdc |

Table 4 General Specifications

| MODEL | 12KW |
|------------------------------------|----------------------------------------------|
| Safety Certification | CE |
| Operating Temperature Range | -10°C to 50°C |
| Storage temperature | -15°C~ 60°C |
| Humidity | 5% to 95% Relative Humidity (Non-condensing) |
| Dimension (D*W*H), mm | 147.4x 432.5 x 553.6 |
| Net Weight, kg | 18.4 |

Table 5 Parallel Specifications

| | |
|----------------------------------------------------|-----------------|
| Max parallel numbers | 12 |
| Circulation Current under No Load Condition | Max 2A |
| Power Unbalance Ratio | <5% @ 100% Load |
| Parallel communication | CAN |
| Transfer time in parallel mode | Max 50ms |
| Parallel Kit | YES |

Note: Parallel feature will be disabled when only PV power is available.

TROUBLE SHOOTING

| Phenomenon and/or Possible cause | What to do |
|--------------------------------------------------------------------------|----------------------------------------------------------------------------------------------------------------------------------------------------------------------------------------------------------------------------------------------------------------------------------------------------------------------------------------------------------------------------------------------------------------------------------------------------------------------------------------|
| No response while press the main switch. | |
| No Utility power and PV is applied. | Check whether the DC breaker tripped or has not yet turned on? If problem still exists, please contact the service center to repair it. |
| No response while pressing the main switch. | |
| Utility power or PV power exists. | Check whether the AC breaker tripped? Or PV voltage reaches to the operation level? If problem still exists, please contact the service center to repair it. |
| Output turned off, Buzzer beeps continuously, RED LED solid on | |
| F01 shows. Fans abnormal stopped during startup sequence | Please contact service center to replace them. |
| F02 shows. | Configure the PV panels lower than 500V. |
| F03 shows. | Disconnect the Utility and PV power. Then, re-apply again. If over-voltage alarm still sounds, the internal charger might has some problem. Please contact with service center to repair it. |
| F05 shows. | Check and verify if there is any load with short circuit condition? Remove the load and restart the unit again. If problem still exists, please contact the service center to repair it. |
| F14 shows. | Clean the anti-dust filter and keep the unit installed in a well ventilated environment. |
| F18 shows. | Reduce the applied load and restart the unit again. |
| F06, F07, F08, F09, F10, F11, F12, F13, F15, F16, F17, F19 or F20 shows. | Please restart the unit again. If problem still exists, please contact the service center to repair it. |
| F20 shows. | <ol style="list-style-type: none"> Restart the inverter. Check if L/N cables are not connected reversely in all inverters. For parallel system in single phase, make sure the sharing are connected in all inverters. For supporting three-phase system, make sure the sharing cables are connected in the inverters in the same phase, and disconnected in the inverters in different phases. If the problem remains, please contact your installer. |
| F22, F23, or F24 shows. | <ol style="list-style-type: none"> Check if communication cables are connected well and restart the inverter. If the problem remains, please contact your installer. |
| F25 shows. | <ol style="list-style-type: none"> Make sure all inverters share same groups of batteries together. Remove all loads and disconnect AC input and PV input. Then, check battery voltage of all inverters. If the values from all inverters are close, please check if all battery cables are the same length and same material type. Otherwise, please contact your installer to provide SOP to calibrate battery voltage of each inverter. |

| | |
|--------------------------------------------------------------------------|---------------------------------------------------------------------------------------------------------------------------------------------------------------------------------------------------------------------------------------------------------------------------------------------------------------------------------------------------------------------------|
| | If the problem still remains, please contact your installer. |
| F26 shows. | <ol style="list-style-type: none"> 1. Check the utility wiring connection and restart the inverter. 2. Make sure utility starts up at same time. If there are breakers installed between utility and inverters, please be sure all breakers can be turned on AC input at same time. <p>If the problem remains, please contact your installer.</p> |
| F27 shows. | <ol style="list-style-type: none"> 1. Restart the inverter. 2. Remove some excessive loads and re-check load information from LCD of inverters. If the values are different, please check if AC input and output cables are in the same length and material type. <p>If the problem remains, please contact your installer.</p> |
| F28 shows. | <ol style="list-style-type: none"> 1. Switch off the inverter and check LCD setting AC output mode 2. For parallel system in single phase, make sure no 3P1, 3P2 or 3P3 is set. For supporting three-phase system, make sure no "PAL" is set on AC output mode setting 3. If the problem remains, please contact your installer. |
| F29 shows. | <ol style="list-style-type: none"> 1. Check if sharing cables are connected well and restart the inverter. 2. If the problem remains, please contact your installer. |
| Output powered but buzzer beeps per second, RED LED flashing | |
| W07 shows. | Reduce load will release the warning. |
| W08 shows. | Clean the anti-dust filter and keep the unit installed in a well ventilated environment. |
| W09 shows. | Fans abnormal stopped during operation. Please contact service center to replace them. |
| W10 shows. | BMS communication disconnected. Please contact service center to repair it. |
| Output powered but no buzzer and LED flashing. Only record on log | |
| W04 shows. | Charge the battery. |
| W05 shows. | Reduce the load. |
| W06 shows. | Utility voltage lower to a certain level, the output rating will be limited. |
| W11 shows. | Internal communication disconnected. Please contact service center to repair it. |
| W16, W17, W18 or W19 shows. | Check Battery status |
| WiFi mark is not displayed. | |
| Unit can't connect to the APP. | Check the Wi-Fi function enabled and icon available on the LCD then follow the Wi-Fi installation procedure to pair the Wi-Fi module with router and APP. |

Appendix I: Parallel function

1. Introduction

This inverter can be used in parallel with two different operation modes.

1. Parallel operation in single phase is with up to 12 units. The supported maximum output power for 12K model is 144KW/144KVA.
2. Maximum 12 units work together to support three-phase equipment. Maximum 10 units support one phase.

2. Mounting the Unit

When installing multiple units, please follow below chart.

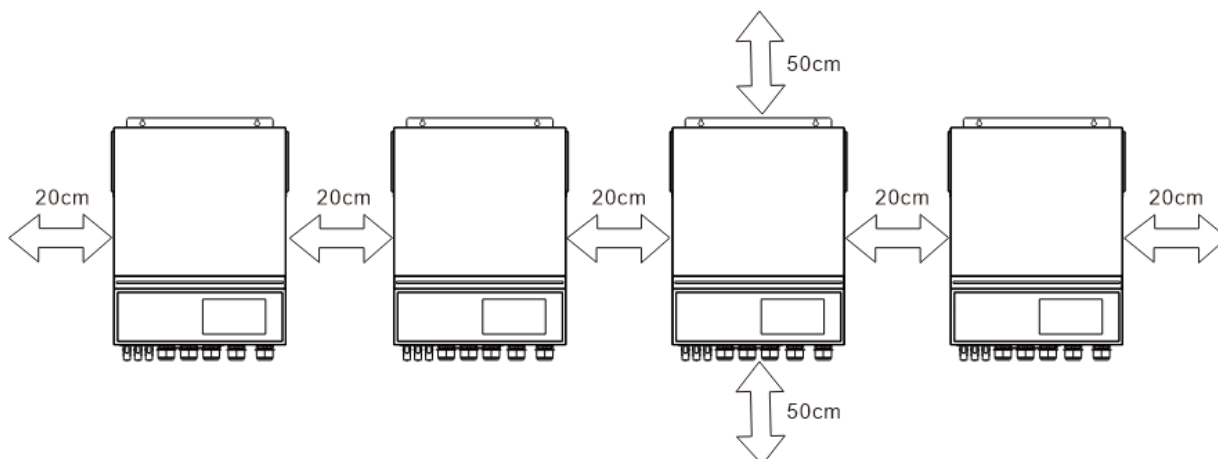

NOTE: For proper air circulation to dissipate heat, allow a clearance of approx. 20 cm to the side and approx. 50 cm above and below the unit. Be sure to install each unit in the same level.

3. Wiring Connection

WARNING: It's REQUIRED to connect battery for parallel operation.

The cable size of each inverter is shown as below:

Recommended battery cable and terminal size for each inverter:

| Model | Wire Size | Cable mm ² | Ring Terminal Dimensions | | Torque value |
|-------|-----------|-----------------------|--------------------------|--------|--------------|
| | | | D (mm) | L (mm) | |
| 12KW | 1*3/0AWG | 85 | 8.4 | 54 | 5 Nm |

Ring terminal:

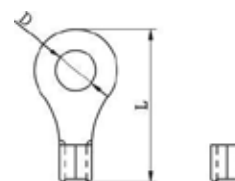

WARNING: Be sure the length of all battery cables is the same. Otherwise, there will be voltage difference between inverter and battery to cause parallel inverters not working.

Recommended AC input and output cable size for each inverter:

| Model | AWG no. | Torque |
|-------|---------|-------------|
| 12KW | 6 AWG | 1.4~ 1.6 Nm |

You need to connect the cables of each inverter together. Take the battery cables for example: You need to use a connector or bus-bar as a joint to connect the battery cables together, and then connect to the battery terminal. The cable size used from joint to battery should be X times cable size in the tables above. "X" indicates the number of inverters connected in parallel.

Regarding AC input and output, please also follow the same principle.

CAUTION!! Please install the breaker at the battery and AC input side. This will ensure the inverter can be securely disconnected during maintenance and fully protected from over current of battery or AC input.

Recommended breaker specification of battery for each inverter:

| | |
|-------|------------|
| Model | 1 unit* |
| 12KW | 300A/70VDC |

*If you want to use only one breaker at the battery side for the whole system, the rating of the breaker should be X times current of 1 unit. "X" indicates the number of inverters connected in parallel.

Recommended breaker specification of AC input with single phase:

| Model | 2 | 3 | 4 | 5 | 6 | 7 | 8 | 9 | 10 | 11 | 12 |
|-------|----------------|----------------|----------------|----------------|----------------|----------------|----------------|----------------|----------------|----------------|----------------|
| 12KW | 120A 230VAC | 180A 230VAC | 240A 230VAC | 300A 230VAC | 360A 230VAC | 420A 230VAC | 480A 230VAC | 540A 230VAC | 600A 230VAC | 660A 230VAC | 720A 230VAC |

Note 1: Also, you can use 60A breaker with only 1 unit and install one breaker at its AC input in each inverter.

Note 2: Regarding three-phase system, you can use 4-pole breaker directly and the rating of the breaker should be compatible with the phase current limitation from the phase with maximum units

Recommended battery capacity

| Inverter parallel numbers | 2 | 3 | 4 | 5 | 6 | 7 | 8 | 9 | 10 | 11 | 12 |
|---------------------------|--------|--------|--------|---------|---------|---------|---------|---------|---------|---------|---------|
| Battery Capacity | 400 AH | 600 AH | 800 AH | 1000 AH | 1200 AH | 1400 AH | 1600 AH | 1800 AH | 2000 AH | 2200 AH | 2400 AH |

WARNING! Be sure that all inverters will share the same battery bank. Otherwise, the inverters will transfer to fault mode.

4. Parallel

4-1. Parallel Operation in Single phase

Two and three inverters in parallel:

Power Connection

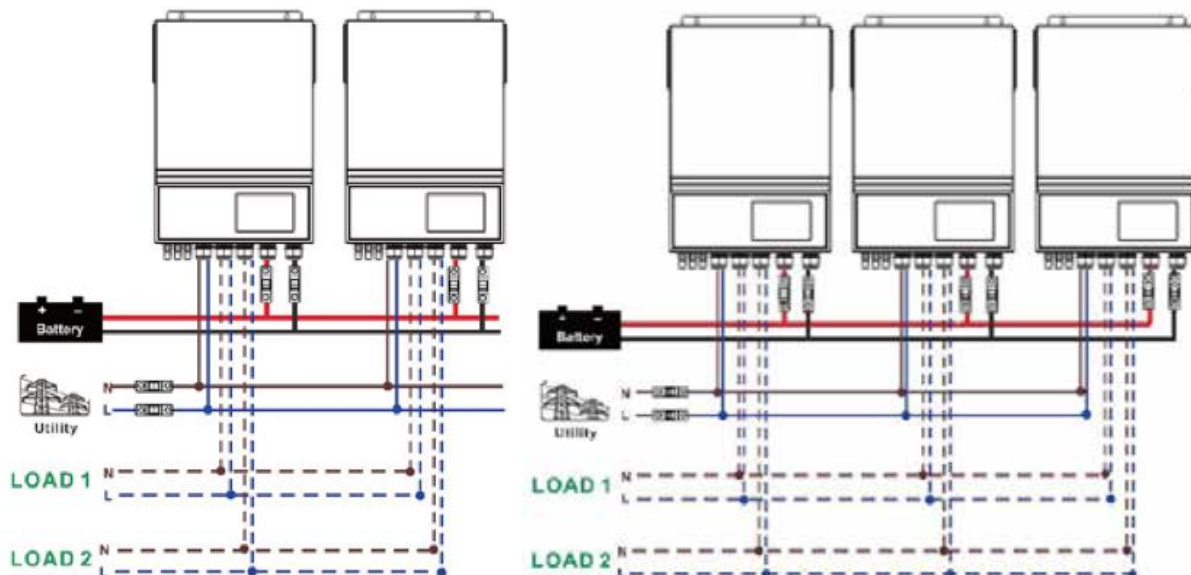

Four inverters in parallel:

Power Connection

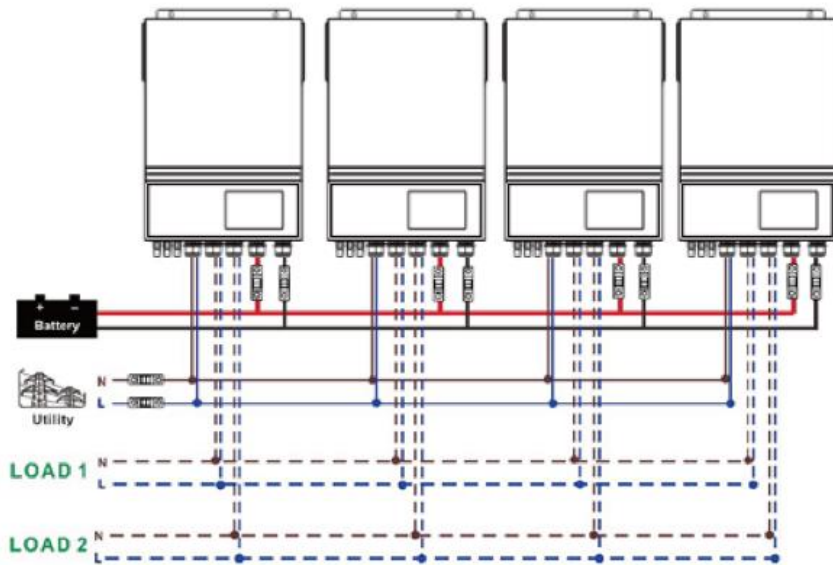

Up to twelve inverters in parallel:

Power Connection

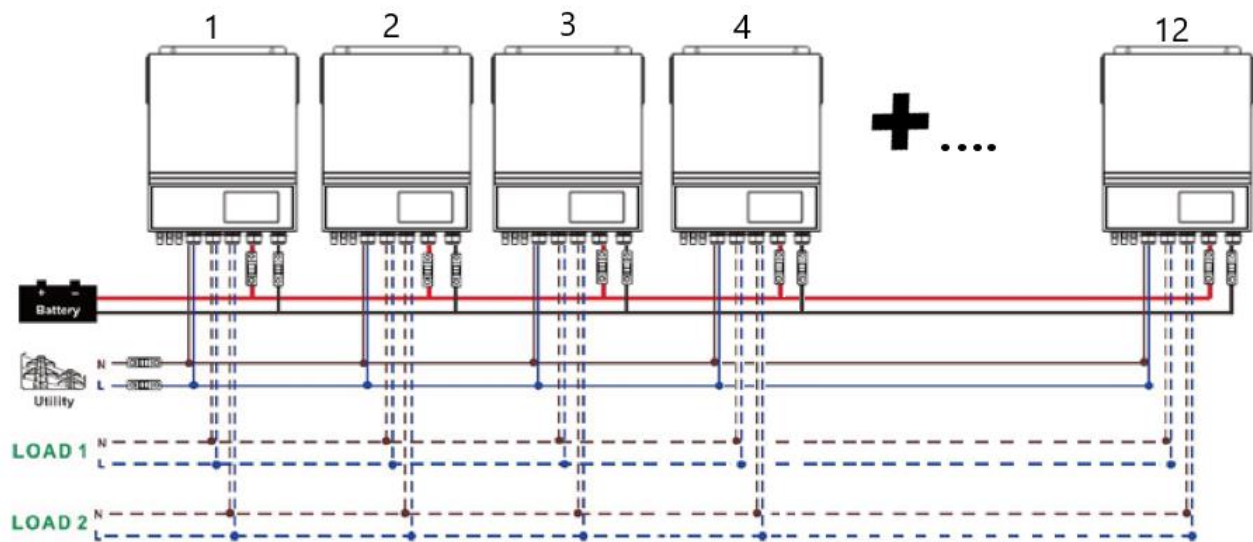

4-2. Support 3-phase equipment

One inverter in each phase:

Power Connection

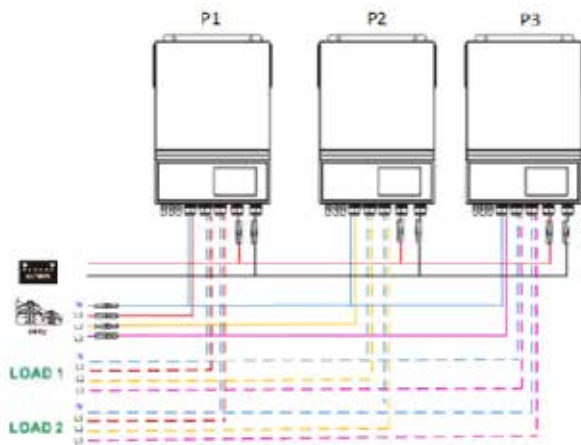

Two inverters in each phase:

Power Connection

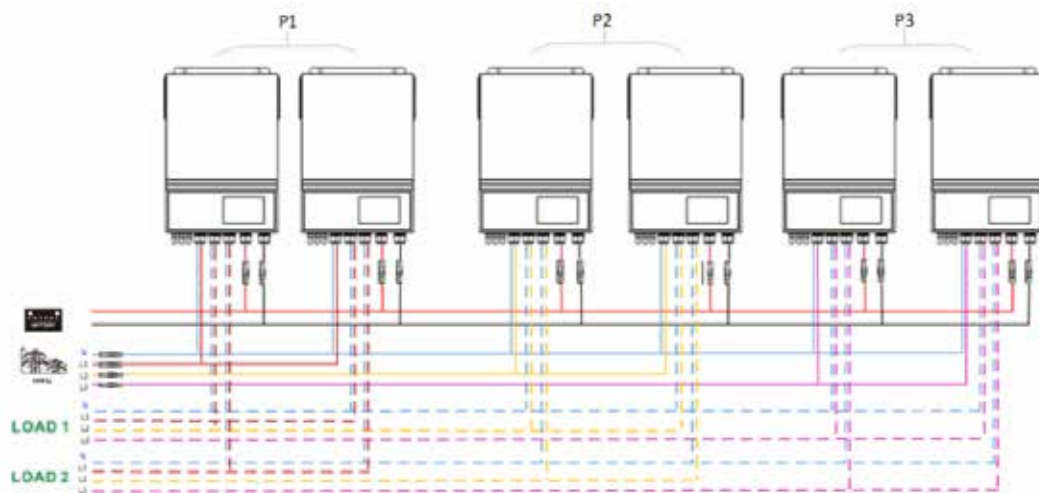

Three to four inverters in each phase:

Power Connection

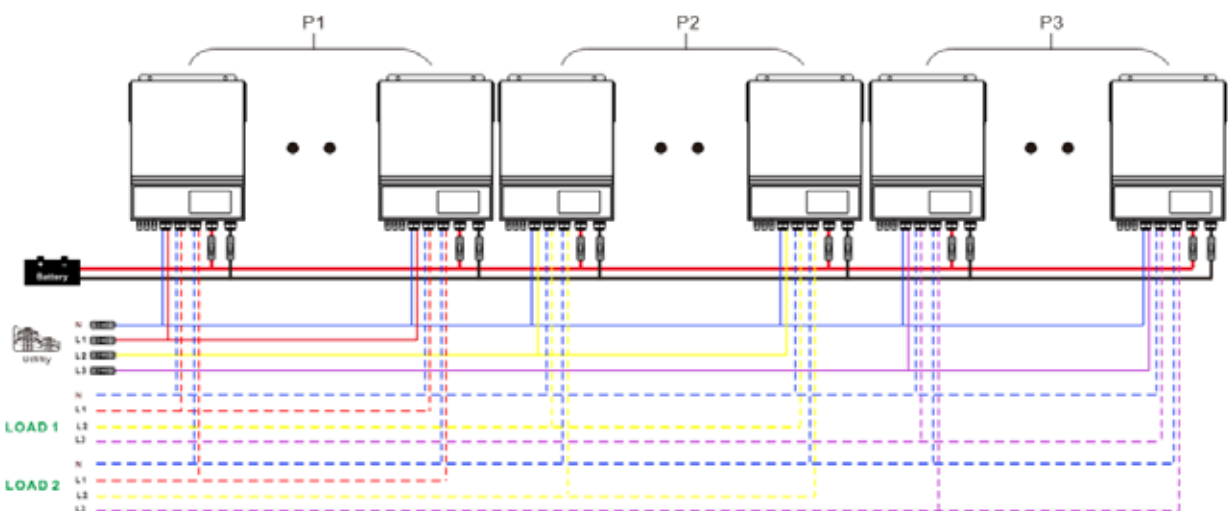

Two inverters in one phase and only one inverter for the remaining phases:

Power Connection

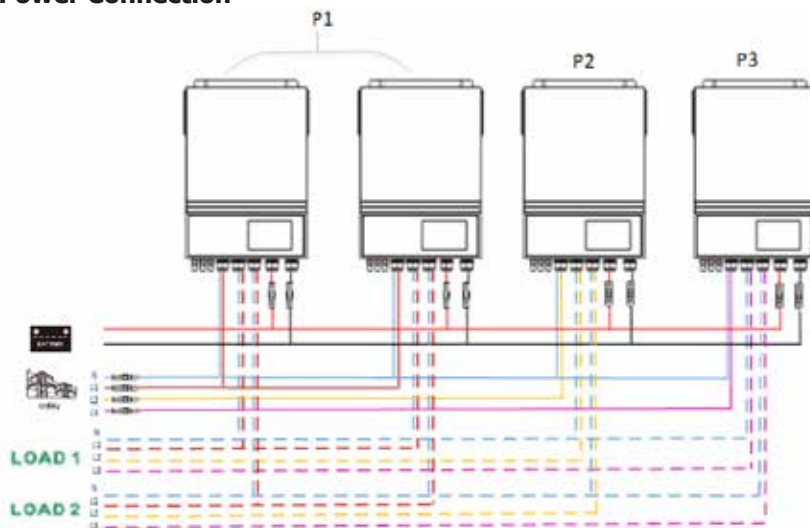

Two inverters in two phases and only one inverter for the remaining phase:

Power Connection

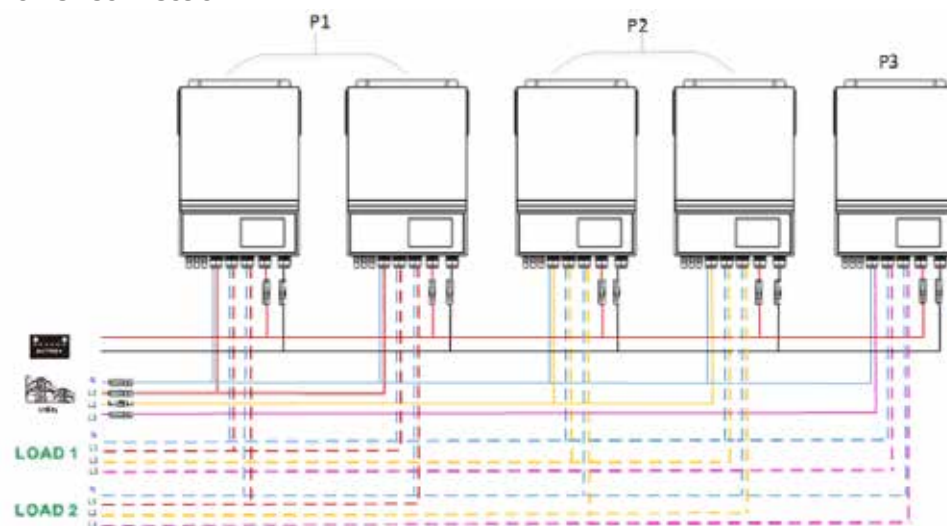

Four inverters in one phase and one inverter for the other two phases:

Power Connection

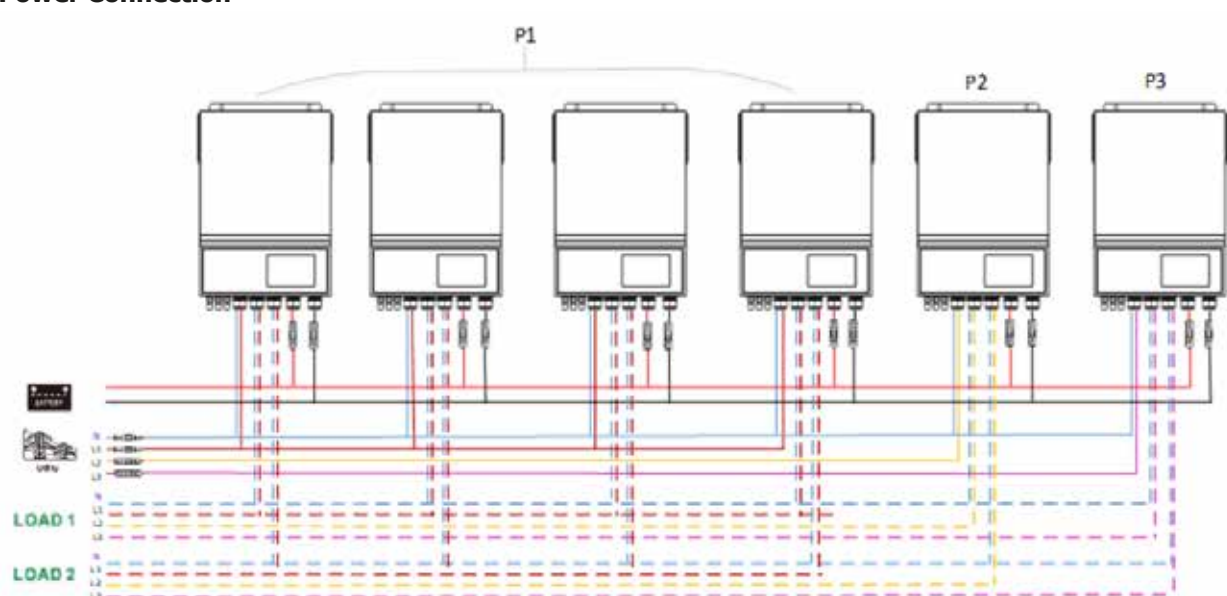

Five to ten inverters in one phase and one inverter for the other two phases:

Power Connection

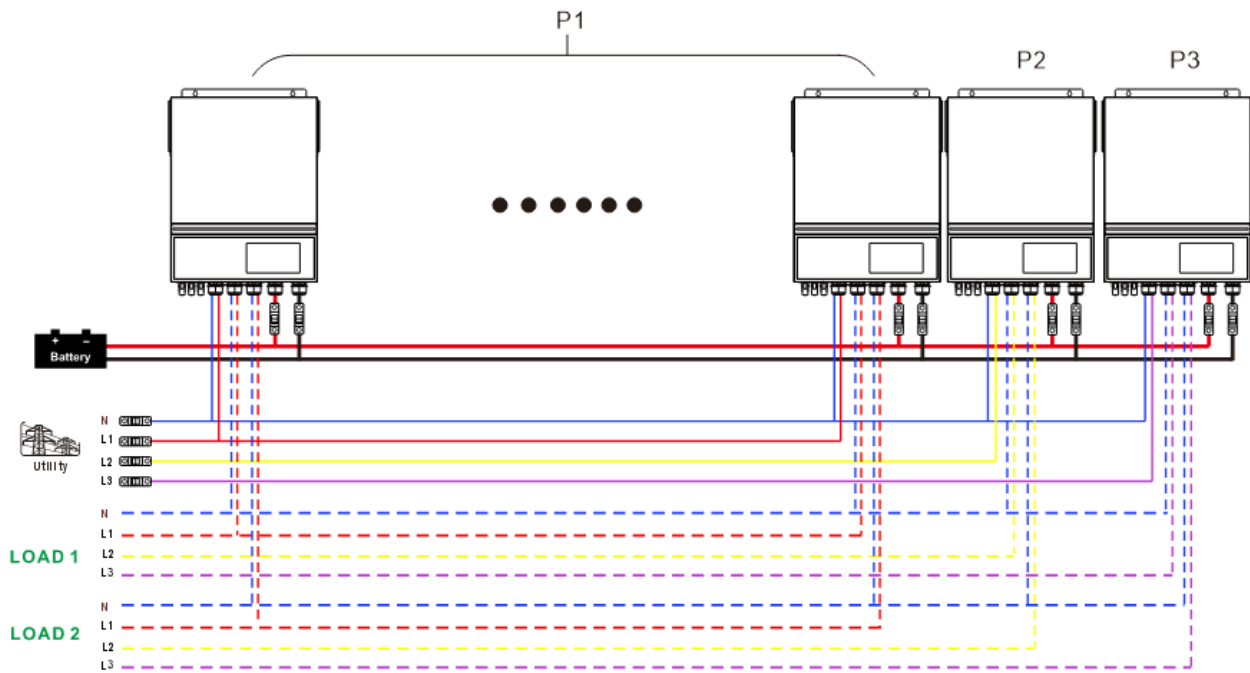

Guide to make parallel and current sharing cable connection

- When inverters are installed on the same phase, the connection method of the parallel cable and the current sharing cable is identical.
- NEVER connect the current sharing cable between the inverters which are in different phases.
- Illustration of cable connections:

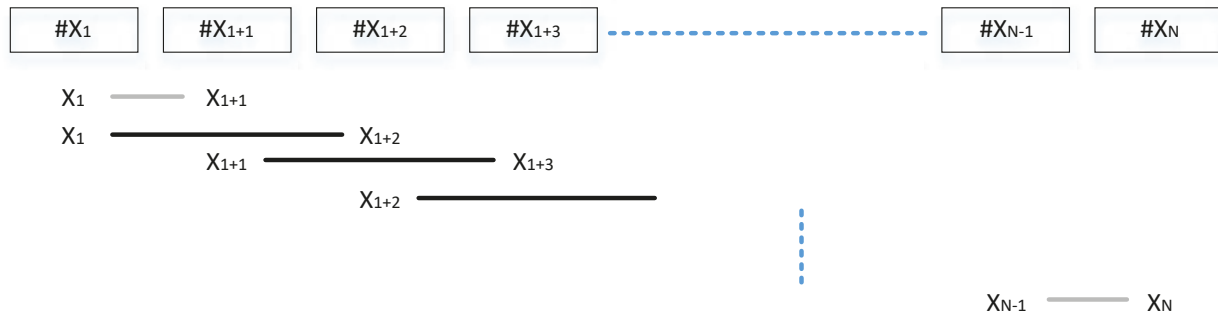

| | |
|------|-------------------------------------------------------------------------------------------------------|
| N=2 | #1 - #2 |
| N=3 | #1 - #2 #1 - #3 #2 - #3 |
| N=4 | #1 - #2 #1 - #3 #2 - #4 #3 - #4 |
| N=5 | #1 - #2 #1 - #3 #2 - #4 #3 - #5 #4 - #5 |
| N=6 | #1 - #2 #1 - #3 #2 - #4 #3 - #5 #4 - #6 #5 - #6 |
| N=7 | #1 - #2 #1 - #3 #2 - #4 #3 - #5 #4 - #6 #5 - #7 #6 - #7 |
| N=8 | #1 - #2 #1 - #3 #2 - #4 #3 - #5 #4 - #6 #5 - #7 #6 - #8 #7 - #8 |
| N=9 | #1 - #2 #1 - #3 #2 - #4 #3 - #5 #4 - #6 #5 - #7 #6 - #8 #7 - #9 #8 - #9 |
| N=10 | #1 - #2 #1 - #3 #2 - #4 #3 - #5 #4 - #6 #5 - #7 #6 - #8 #7 - #9 #8 - #10 #9 - #10 |
| N=11 | #1 - #2 #1 - #3 #2 - #4 #3 - #5 #4 - #6 #5 - #7 #6 - #8 #7 - #9 #8 - #10 #9 - #11 #10 - #11 |
| N=12 | #1 - #2 #1 - #3 #2 - #4 #3 - #5 #4 - #6 #5 - #7 #6 - #8 #7 - #9 #8 - #10 #9 - #11 #10 - #12 #11 - #12 |

Example of 2, 3, 4 units paralleled in a single phase system

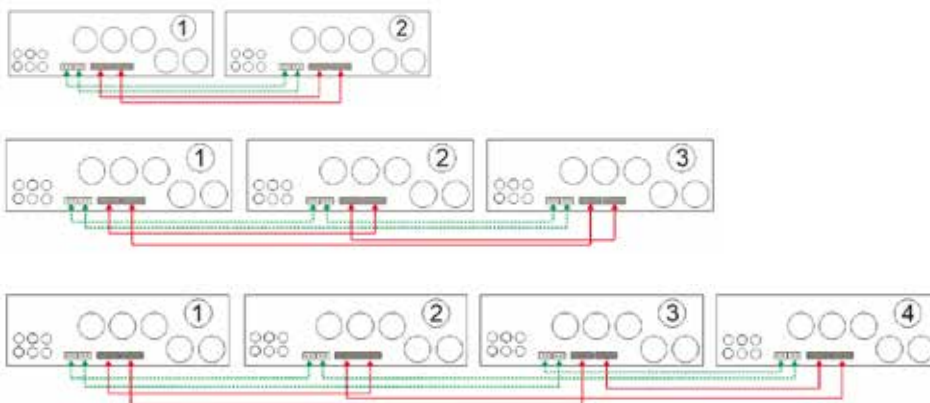

Exampe of 3, 5, 6 units paralleled in a three phase system
 (1 unit for P1, 1 unit for P2, 1 unit for P3)

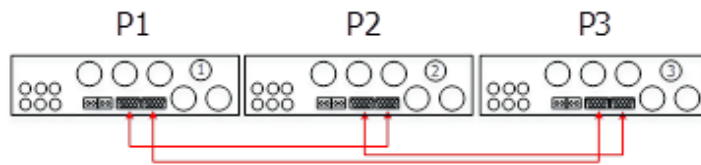

(2 units for P1, 2 units for P2, 1 unit for P3)

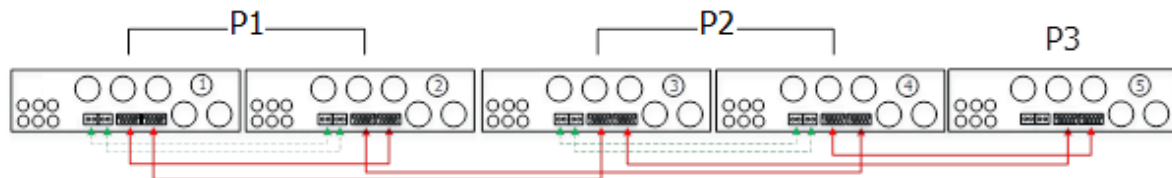

(2 units for P1, 2 units for P2, 2 units for P3)

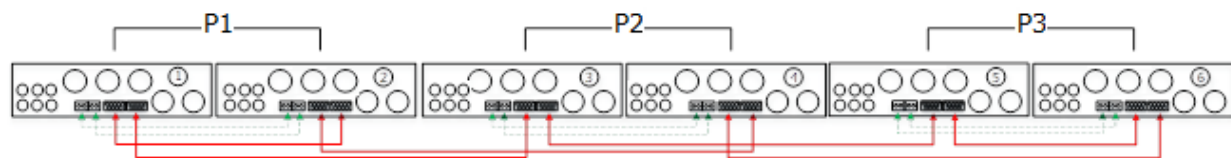





5. PV Connection

Please refer to user manual of single unit for PV Connection.

CAUTION: Each inverter should connect to PV modules separately.

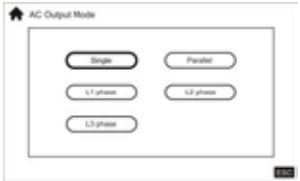
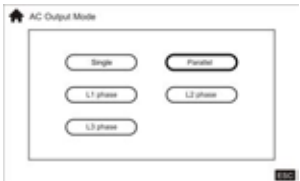
6. LCD Setting and Display

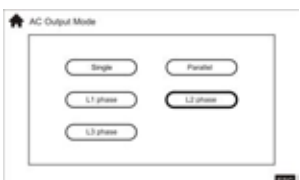
Setting Program:

| Description | Selectable option | |
|---------------------------------------------------------------------------------------------------------------------------------------------|------------------------------------------------------------------------------------------------------|----------------------------------------------------------------------------------------------------------------------------------------------------------------------------------------------------------------------------------------------------------------------------------------------------------------------------------------------------------|
| AC output mode *This setting is able to set up only when the inverter is in standby mode. Be sure that on/off switch is in "OFF" status. | Single  | When the unit is operated alone, please select "Single" |
| | Parallel  | When the units are used in parallel for single phase application, please select "Parallel". Please refer to 4-1 for detailed information. |
| | L1 phase:  | When the units are operated in 3-phase application, please choose phase to define each inverter. It is required to have at least 3 inverters or maximum 12 inverters to support three-phase equipment. It's required to have at least one inverter in each phase or it's up to 10 inverters in one phase. Please refers to 4-2 for detailed information. |
| | L2 phase:  | Please select "L1 phase" for the inverters connected to L1 phase, "L2 phase" for the inverters connected to L2 phase and "L3 phase" for the inverters connected to L3 phase. |
| | L3 phase:  | Be sure to connect share current cable to units which are on the same phase. Do NOT connect share current cable between units on different phases. |

Code Reference:

| Description | Icon on |
|-----------------------------------|---------|
| Unidentified unit master or slave | |
| Master unit | |
| Slave unit | |
| L1 phase | |
| L2 phase | |
| L3 phase | |

7. Commissioning

Parallel in single phase

Step 1: Check the following requirements before commissioning:

- Correct wire connection
- Ensure all breakers in Line wires of load side are open and each Neutral wires of each unit are connected together.

Step 2: Turn on each unit and set "PAL" in LCD setting of each unit. And then shut down all units.

NOET: It's necessary to turn off switch when setting LCD program. Otherwise, the setting cannot be programmed.

Step 3: Turn on each unit.

| LCD display in Master unit | LCD display in Slave unit |
|----------------------------|---------------------------|
| | |
| | |

NOTE: Master and slave units are randomly defined.

Step 4: Switch on all AC breakers of Line wires in AC input. It's better to have all inverters connect to utility at the same time. If not, it will display fault 82 in following-order inverters. However, these inverters will automatically restart. If detecting AC connection, they will work normally.

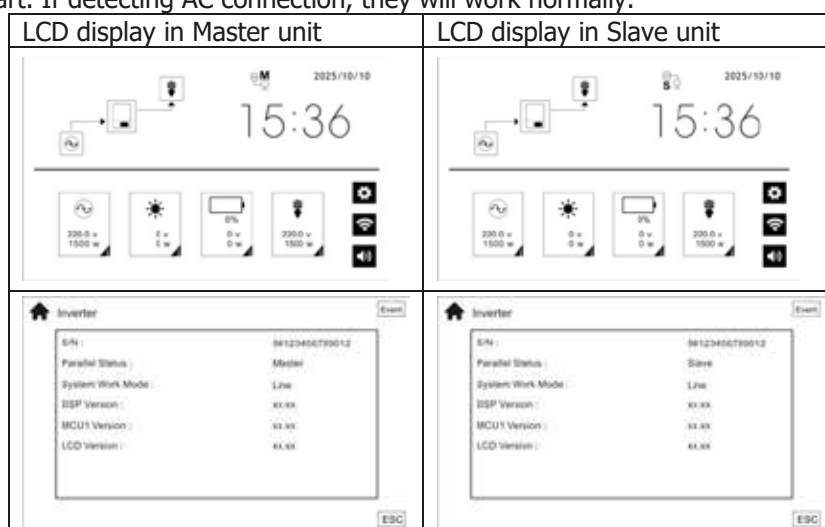

Step 5: If there is no more fault alarm, the parallel system is completely installed.

Step 6: Please switch on all breakers of Line wires in load side. This system will start to provide power to the load.

Support three-phase equipment

Step 1: Check the following requirements before commissioning:

- Correct wire connection
- Ensure all breakers in Line wires of load side are open and each Neutral wires of each unit are connected together.

Step 2: Turn on all units and configure AC output mode as P1, P2 and P3 sequentially. And then shut down all units.

NOET: It's necessary to turn off switch when setting LCD program. Otherwise, the setting cannot be programmed.

Step 3: Turn on all units sequentially.

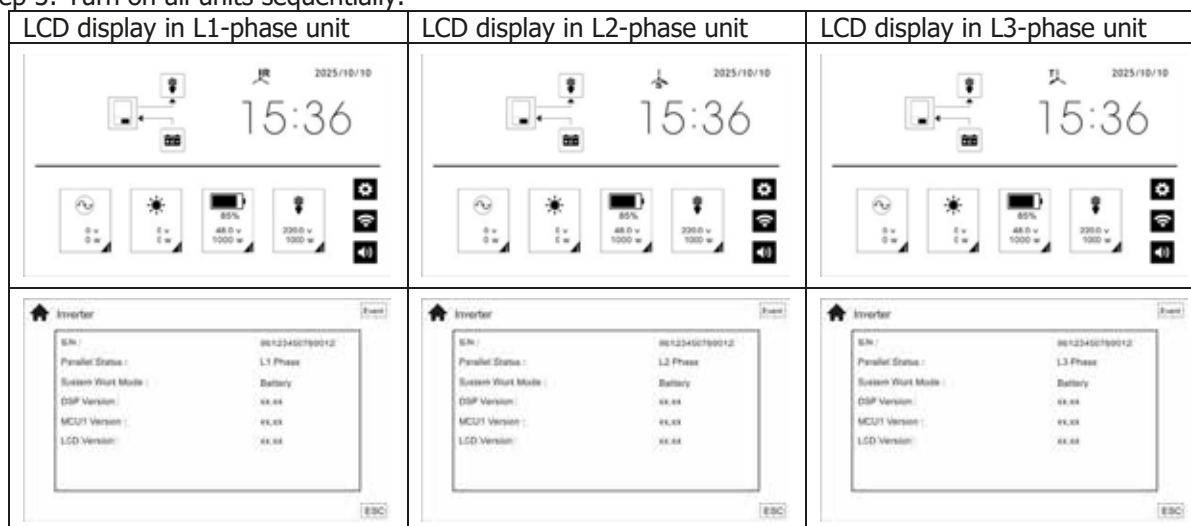

Step 4: Switch on all AC breakers of Line wires in AC input. If AC connection is detected and three phases are matched with unit setting, they will work normally. Otherwise, they will not work in line mode.

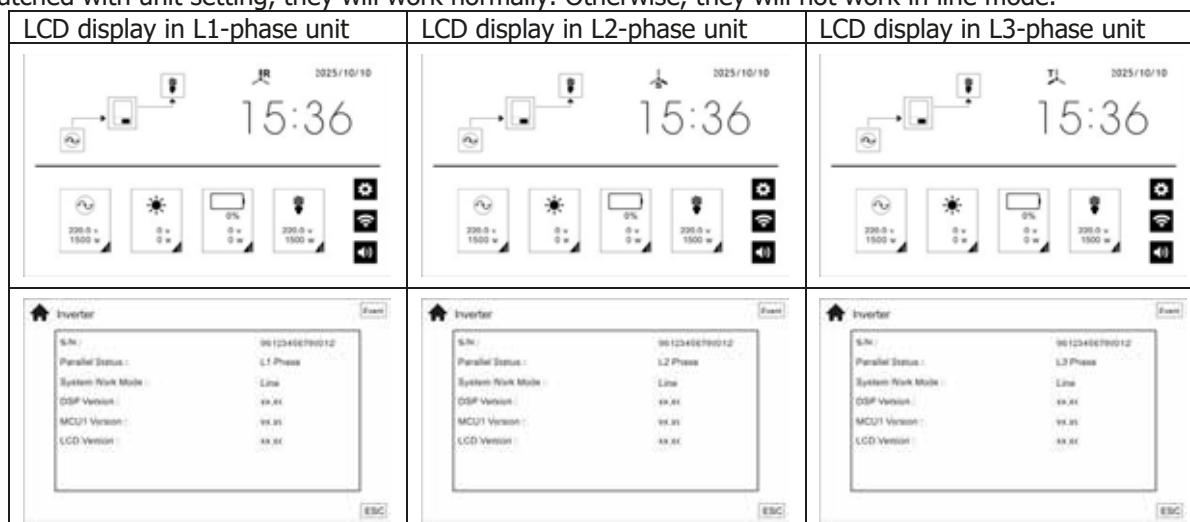

Step 5: If there is no more fault alarm, the system to support 3-phase equipment is completely installed.

Step 6: Please switch on all breakers of Line wires in load side. This system will start to provide power to the load.

Note 1: To avoid overload occurring, before turning on breakers in load side, it's better to have whole system in operation first.

Note 2: Transfer time for this operation exists. Power interruption may happen to critical devices, which cannot bear transfer time.

8. Trouble shooting

| Situation | | Solution |
|------------|--------------------------------------------------------|---------------------------------------------------------------------------------------------------------------------------------------------------------------------------------------------------------------------------------------------------------------------------------------------------------------------------------------------------------------------------------------------------------------------------------------------------------------------------------------------------------------------------------------------------|
| Fault Code | Fault Event Description | |
| 20 | Current feedback into the inverter is detected. | <ol style="list-style-type: none"> 1. Restart the inverter. 2. Check if L/N cables are not connected reversely in all inverters. 3. For parallel system in single phase, make sure the sharing are connected in all inverters. 4. For supporting three-phase system, make sure the sharing cables are connected in the inverters in the same phase, and disconnected in the inverters in different phases. 5. If the problem remains, please contact your installer. |
| 33 | The firmware version of each inverter is not the same. | <ol style="list-style-type: none"> 1. Update all inverter firmware to the same version. 2. Check the version of each inverter via LCD setting and make sure the CPU versions are same. If not, please contact your installer to provide the firmware to update. 3. After updating, if the problem still remains, please contact your installer. |
| 29 | The output current of each inverter is different. | <ol style="list-style-type: none"> 1. Check if sharing cables are connected well and restart the inverter. 2. If the problem remains, please contact your installer. |
| 22 | CAN data loss | <ol style="list-style-type: none"> 1. Check if communication cables are connected well and restart the inverter. 2. If the problem remains, please contact your installer. |
| 23 | Host data loss | |
| 24 | Synchronization data loss | |
| 25 | The battery voltage of each inverter is not the same. | <ol style="list-style-type: none"> 1. Make sure all inverters share same groups of batteries together. 2. Remove all loads and disconnect AC input and PV input. Then, check battery voltage of all inverters. If the values from all inverters are close, please check if all battery cables are the same length and same material type. Otherwise, please contact your installer to provide SOP to calibrate battery voltage of each inverter. 3. If the problem still remains, please contact your installer. |
| 26 | AC input voltage and frequency are detected different. | <ol style="list-style-type: none"> 1. Check the utility wiring connection and restart the inverter. 2. Make sure utility starts up at same time. If there are breakers installed between utility and inverters, please be sure all breakers can be turned on AC input at same time. 3. If the problem remains, please contact your installer. |
| 27 | AC output current unbalance | <ol style="list-style-type: none"> 1. Restart the inverter. 2. Remove some excessive loads and re-check load information from LCD of inverters. If the values are different, please check if AC input and output cables are in the same length and material type. 3. If the problem remains, please contact your installer. |
| 28 | AC output mode setting is different. | <ol style="list-style-type: none"> 1. Switch off the inverter, check LCD setting on the AC output mode. 2. For parallel system in single phase, make sure no L1 phase, L2 phase or L3 phase is set on "AC Output Mode". 3. For supporting three-phase system, please select L1, L2 or L3 phase, not "Parallel". 4. If the problem remains, please contact your installer. |

Appendix II: BMS Communication Installation

1. Introduction

If connecting to lithium battery, it is recommended to purchase a custom-made RJ45 communication cable. Please check with your dealer or integrator for details.

This custom-made RJ45 communication cable delivers information and signal between lithium battery and the inverter. These information are listed below:

- Re-configure charging voltage, charging current and battery discharge cut-off voltage according to the lithium battery parameters.
- Have the inverter start or stop charging according to the status of lithium battery.

2. Pin Assignment for BMS Communication Port

| | Definition |
|-------|------------|
| PIN 1 | RS232TX |
| PIN 2 | RS232RX |
| PIN 3 | RS485B |
| PIN 4 | NC |
| PIN 5 | RS485A |
| PIN 6 | CANH |
| PIN 7 | CANL |
| PIN 8 | GND |

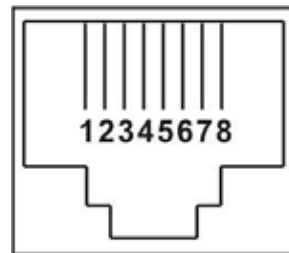

3. Lithium Battery Communication Configuration

LIO-4810-150A

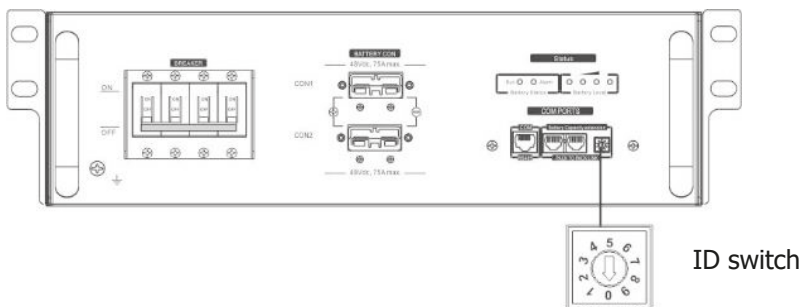

ESS LIO-I 4810

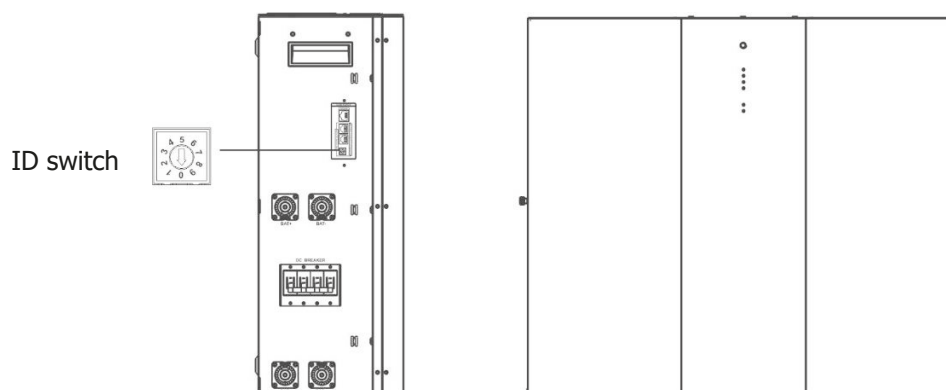

ID Switch indicates the unique ID code for each battery module. It's required to assign a unique ID to each battery module for normal operation. We can set up the ID code for each battery module by rotating the PIN number on the ID switch. From number 0 to 9, the number can be random; no particular order. Maximum 10 battery modules can be operated in parallel.

PYLONTECH

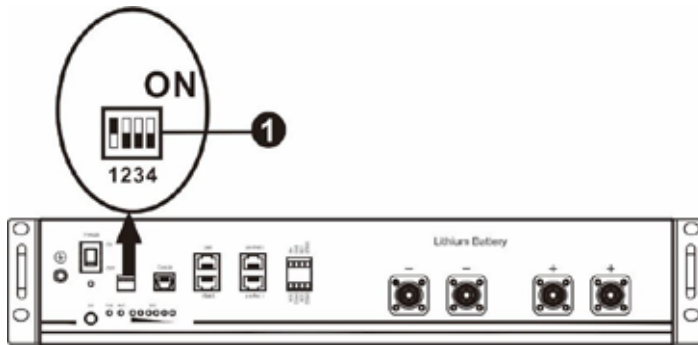

① Dip Switch: There are 4 Dip Switches that sets different baud rate and battery group address. If switch position is turned to the "OFF" position, it means "0". If switch position is turned to the "ON" position, it means "1".

Dip 1 is "ON" to represent the baud rate 9600.

Dip 2, 3 and 4 are reserved for battery group address.

Dip switch 2, 3 and 4 on master battery (first battery) are to set up or change the group address.

NOTE: "1" is upper position and "0" is bottom position.

| Dip 1 | Dip 2 | Dip 3 | Dip 4 | Group address |
|-------------------------------|-------|-------|-------|----------------------------------------------------------------------------------------------------------------------------------------------|
| Restart to take effect | 0 | 0 | 0 | Single group only. It's required to set up master battery with this setting and slave batteries are unrestricted. |
| | 1 | 0 | 0 | Multiple group condition. It's required to set up master battery on the first group with this setting and slave batteries are unrestricted. |
| | 0 | 1 | 0 | Multiple group condition. It's required to set up master battery on the second group with this setting and slave batteries are unrestricted. |
| | 1 | 1 | 0 | Multiple group condition. It's required to set up master battery on the third group with this setting and slave batteries are unrestricted. |
| | 0 | 0 | 1 | Multiple group condition. It's required to set up master battery on the fourth group with this setting and slave batteries are unrestricted. |
| | 1 | 0 | 1 | Multiple group condition. It's required to set up master battery on the fifth group with this setting and slave batteries are unrestricted. |

NOTE: The maximum groups of lithium battery is 5 and for maximum number for each group, please check with battery manufacturer.

4. Installation and Operation

LIO-4810-150A/ESS LIO-I 4810

After ID no. is assigned for each battery module, please set up LCD panel in inverter and install the wiring connection as following steps.

Step 1: Use supplied RJ11 signal cable to connect into the extension port (P1 or P2).

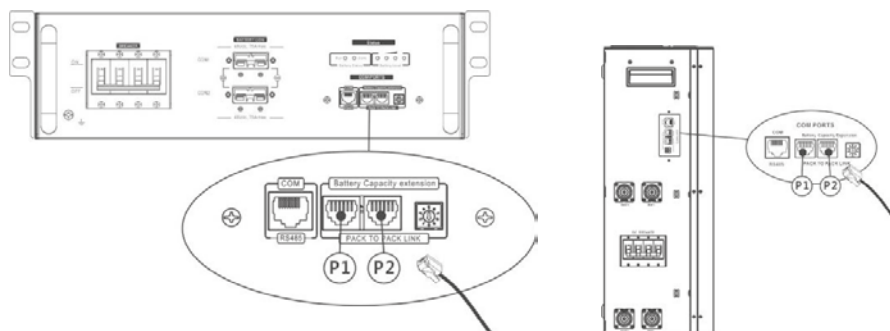

Step 2: Use supplied RJ45 cable (from battery module package) to connect inverter and Lithium battery.

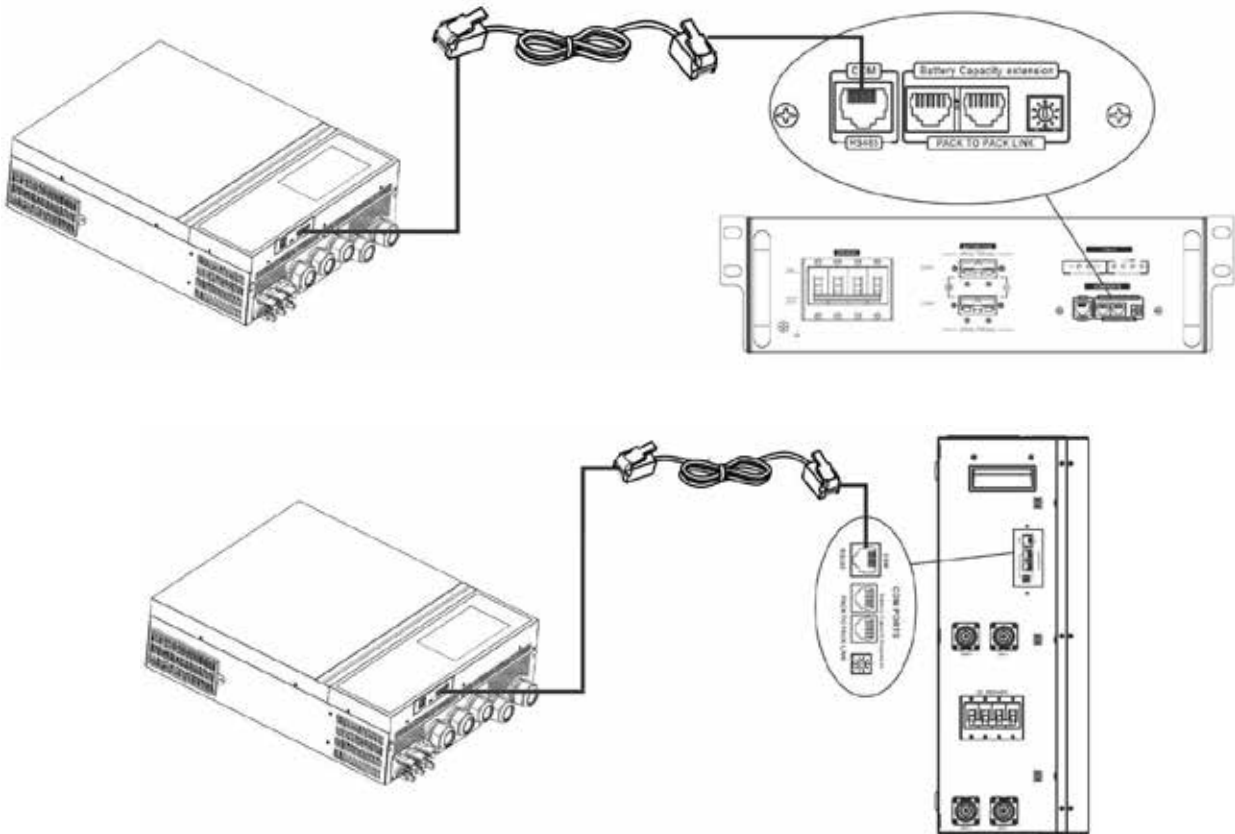

*** For multiple battery connection, please check battery manual for the details.**

Note for parallel system:

1. Only support common battery installation.
2. Use custom-made RJ45 cable to connect any inverter (no need to connect to a specific inverter) and Lithium battery. Simply set this inverter battery type to "LIB". Others should be "USE".

Step 3: Turn the breaker switch "ON". Now, the battery module is ready for DC output.



Step 4: Press Power on/off button on battery module for 5 secs, the battery module will start up.

*If the manual button cannot be approached, just simply turn on the inverter module. The battery module will be automatically turned on.

Step 5: Turn on the inverter.



Step 6. Be sure to select battery type as "LIB" in LCD.

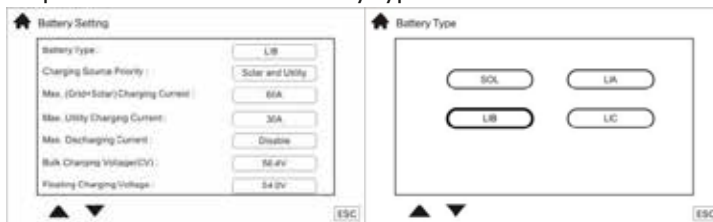

If communication between the inverter and battery is successful, The communication status on the BMS page will show connect.

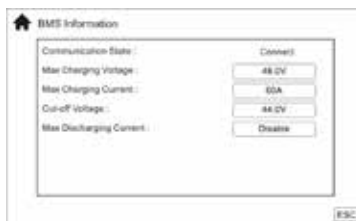

PYLONTECH

After configuration, please install LCD panel with inverter and Lithium battery with the following steps.

Step 1. Use custom-made RJ45 cable to connect inverter and Lithium battery.

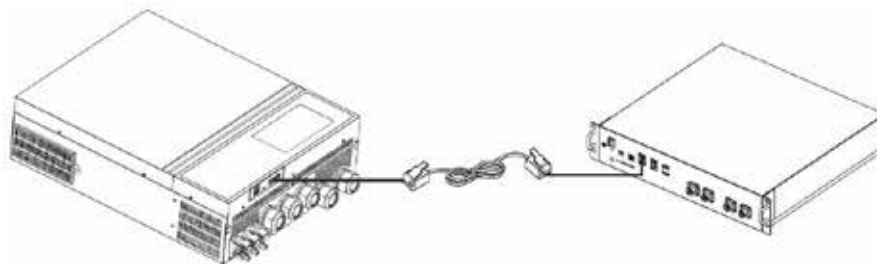

Note for parallel system:

1. Only support common battery installation.
2. Use custom-made RJ45 cable to connect any inverter (no need to connect to a specific inverter) and Lithium battery. Simply set this inverter battery type to "PYL". Others should be "USE".

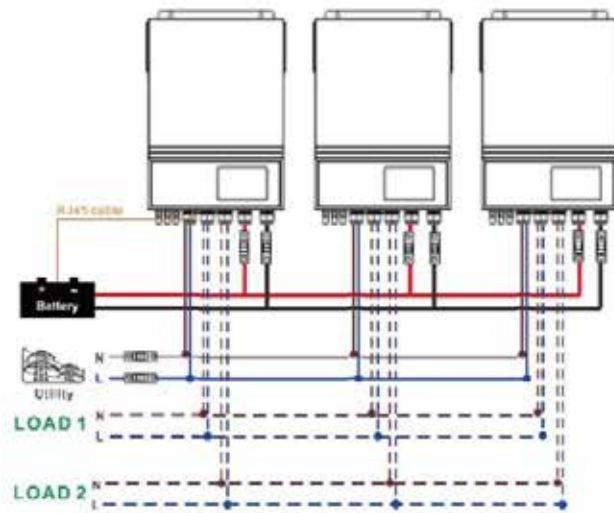

Step 2. Switch on Lithium battery.

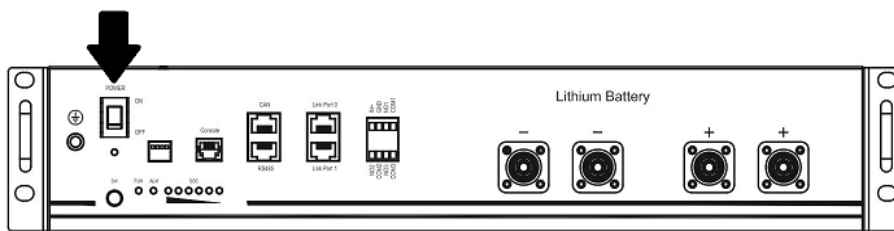

Step 3. Press more than three seconds to start Lithium battery, power output ready.

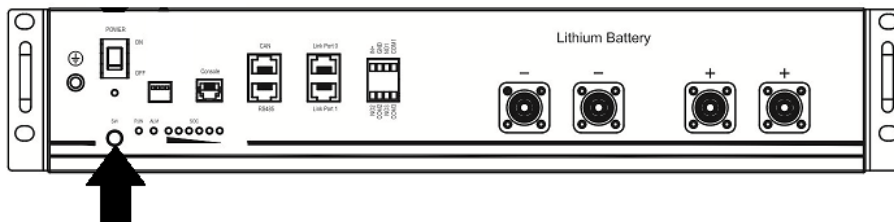

Step 4. Turn on the inverter.



Step 5. Be sure to select battery type as "PYL" in LCD.

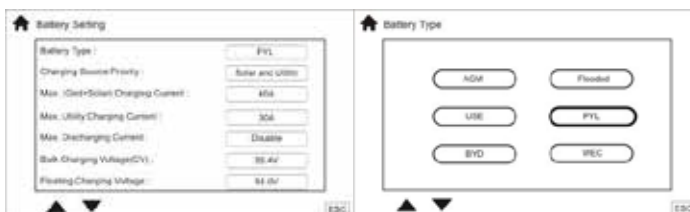

If communication between the inverter and battery is successful, The communication status on the BMS page will show connect.

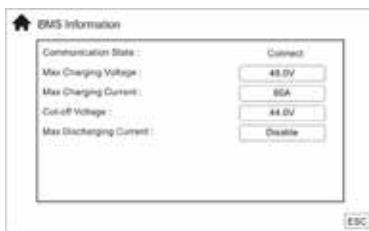

Active Function

This function is to activate lithium battery automatically while commissioning. After battery wiring and commissioning is successfully, if battery is not detected, the inverter will automatically activate battery if the inverter is powered on.

Appendix III: The Wi-Fi Operation Guide

1. Introduction

Wi-Fi module can enable wireless communication between solar inverters and the monitoring platform. Users can remotely monitor and control their inverters when they combine the Wi-Fi module with Energy-Mate APP. The App uses the Wi-Fi chip to provide remote monitoring data services, which is beneficial for the daily data monitoring of the inverter, querying the real-time data in the device, sending commands from the device, and operating the device remotely. The app is available for both iOS and Android.

The major functions of this APP:

- Delivers device status during normal operation.
- Allows to configure device setting after installation.
- Notifies users when a warning or alarm occurs.
- Allows users to query inverter history data.



2. Energy-Mate App

2-1. Download and install APP

Please find "Energy-Mate" app from Apple® store or Google® Play Store. Install this app in your mobile phone.



Or scan the following QR code with your smart phone and download Energy-Mate App.



(Android system)



(iOS system)

2-2. Initial Setup

You can choose local Wi-Fi or Bluetooth to configure the Wi-Fi module network through Energy-mate APP.

Local Wi-Fi Configuration

If you have configured the network through Bluetooth, please skip this section.

- Turn on the unit.
- Open the Wi-Fi settings from your smart phone.
- Connect your smart phone to the Wi-Fi module. The Wi-Fi module PN number is 18 digits.
- Default password for the Wi-Fi module is: 12345678.

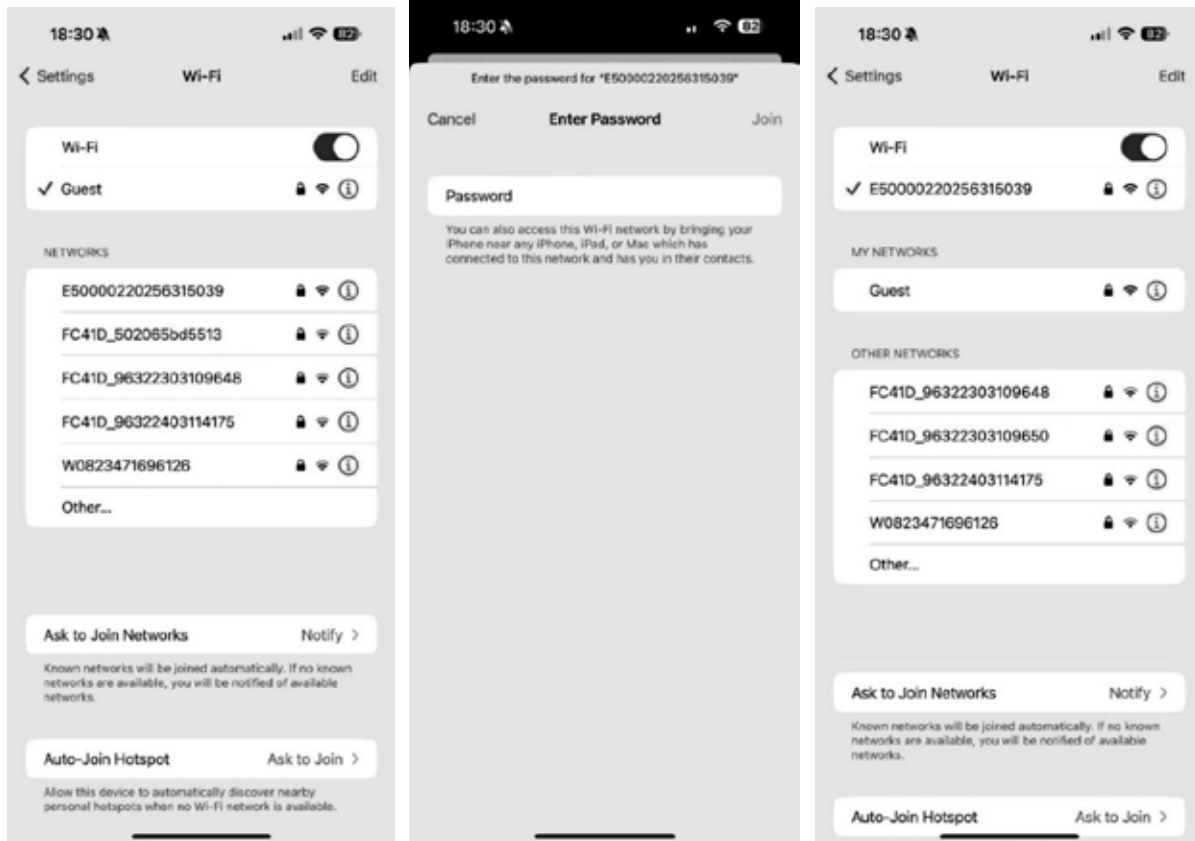

- Once the Wi-Fi connection is successful, click the Energy-Mate APP installed in the phone to enter the login page. Then, click the "Toolbox" and choose "Wi-Fi Config" to enter the Wi-Fi configuration page.

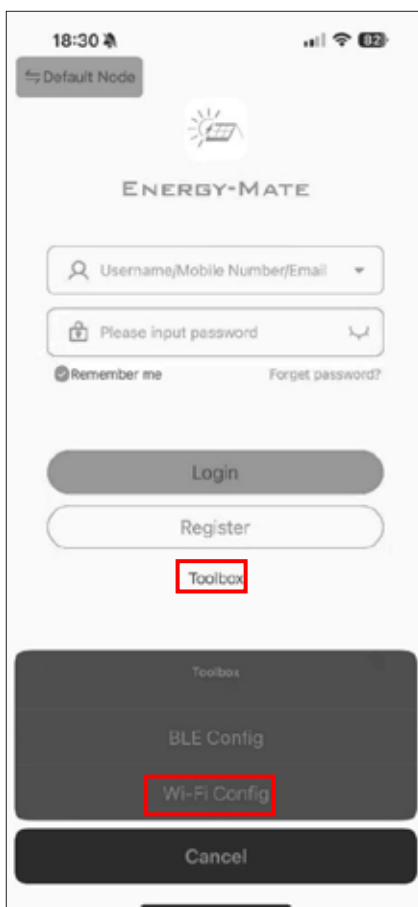

- After entering the Wi-Fi configuration page, please note that the connected Wi-Fi name **must** be the **same as your Wi-Fi module PN number**, and the status **must** be **connected**. If not, please return to the login page, connect your smart phone to the Wi-Fi module, and re-enter the Wi-Fi configuration page.

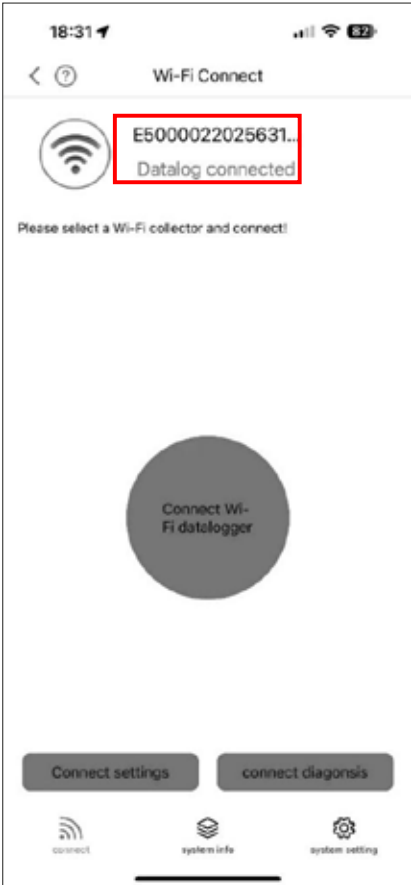
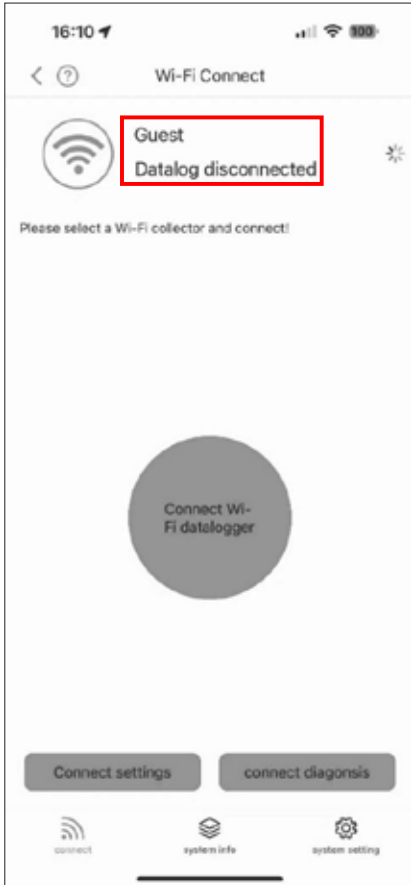
| The Wi-Fi module connection is successfully | The Wi-Fi module connection failed |
|------------------------------------------------------------------------------------------------------------------------------------------------------|----------------------------------------------------------------------------------------------------------------------------------------------------------------------------------------------------------------------|
| <p>You can proceed to the next step to configure the network.</p>  | <p>Please return to the login page, connect your smart phone to the Wi-Fi module, and re-enter the Wi-Fi configuration page.</p>  |

- Click "Connect settings" to manually enter the router name or click  to choose the router name. Then, enter the router password and click the "Setting" to complete the setting.
The Wi-Fi module only could connect the router at **2.4GHz**.

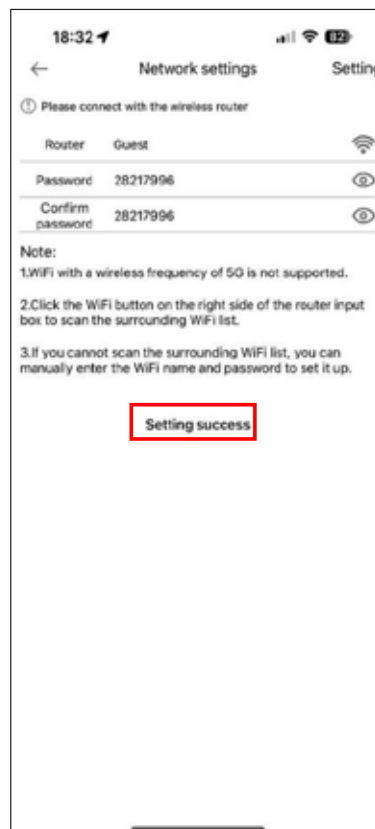
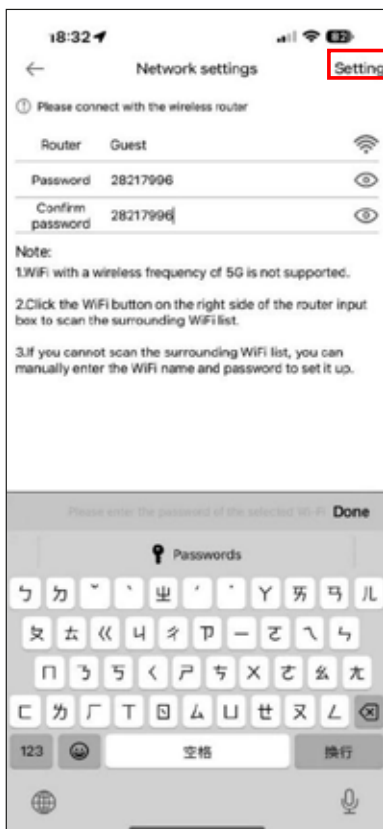
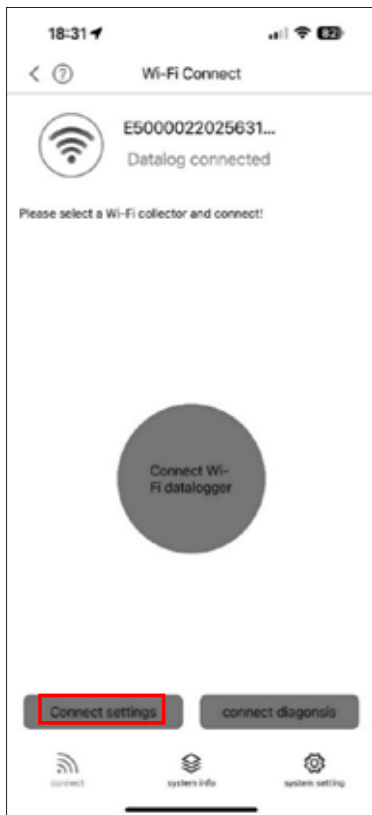

- Click to return to the Wi-Fi configuration page. Click "Connect diagnosis" to check the connection status.

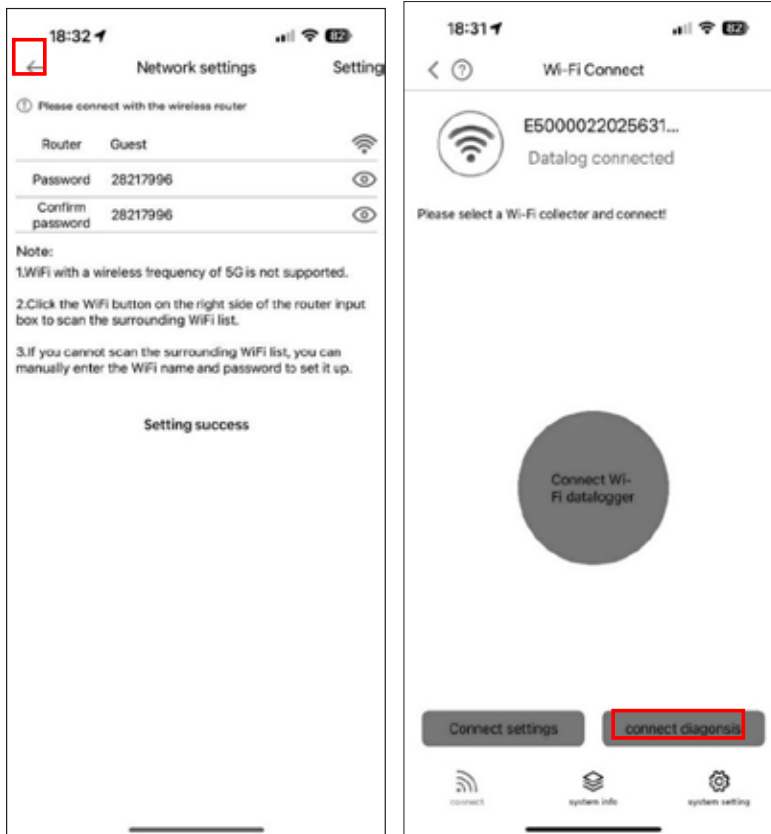

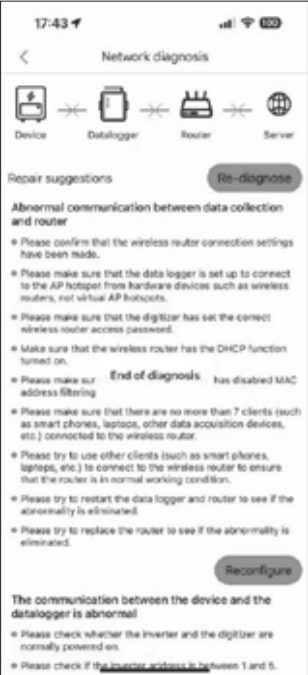
| The configuration is successfully | The configuration failed |
|--------------------------------------------------------------------------------------------------------------------------------------------------------|-----------------------------------------------------------------------------------------------------------------------------------------------------------------------------------------------------------|
| <p>Green lines between device, datalogger, router, and server.</p>  | <p>Red crosses between device, datalogger, router, and server. Please refer to APP instructions to re-configure.</p>  |

- After Wi-Fi configuration, please **forget** the Wi-Fi module of the Wi-Fi connection on the smartphone to avoid automatic connection and unable to access the network. The login page will prompt "Server not found".

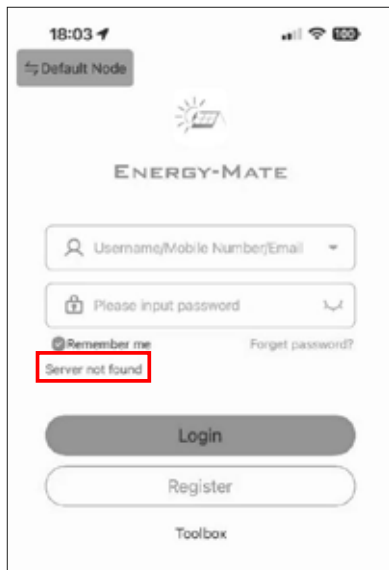

Bluetooth Configuration

If you have configured the network through Wi-Fi, please skip this section.

- Turn on the unit.
- Open the Bluetooth from your smart phone.
- Click the Energy-Mate APP installed in the phone to enter the login page. Then, click the "Toolbox" and choose "BLE Config" to enter the Bluetooth configuration page.

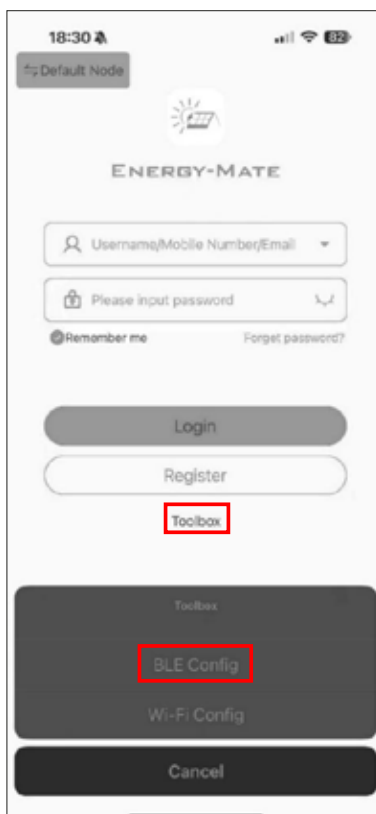

- Connect your smart phone to the Wi-Fi module through Bluetooth.

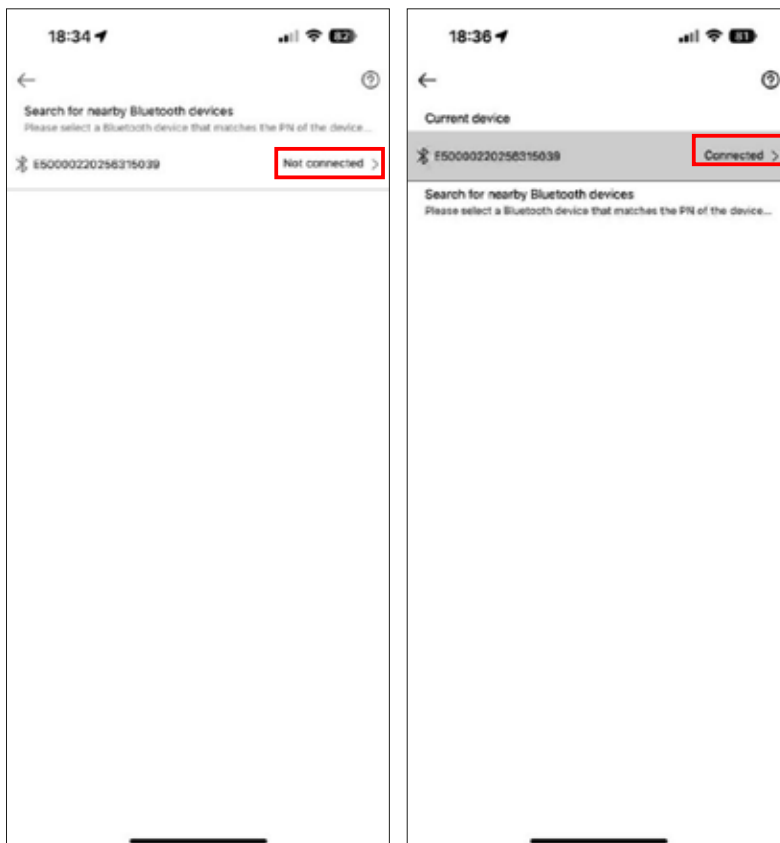

- Manually enter the router name or click to choose the router name, enter the router password, and then click the "Setting" to complete the setting.

The Wi-Fi module only could connect the router at **2.4GHz**.

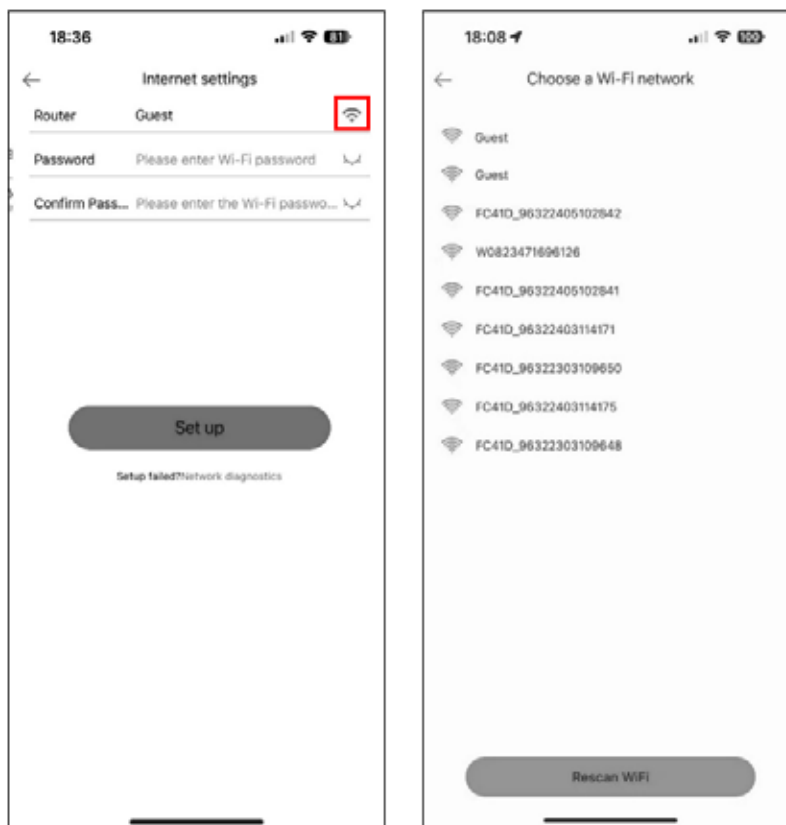

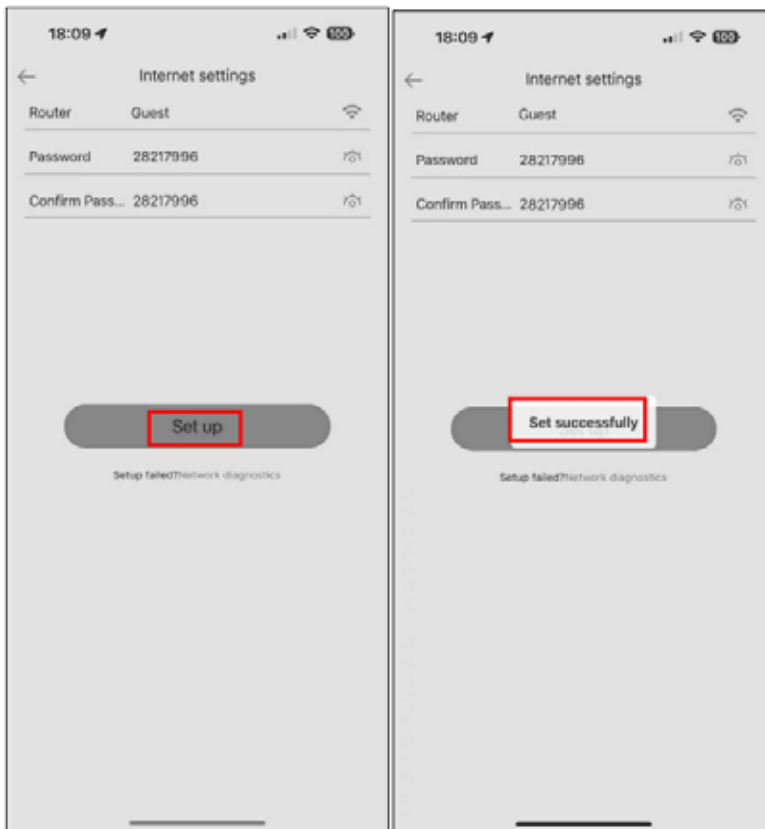

- Click "Network diagnosis" to check the connection status.

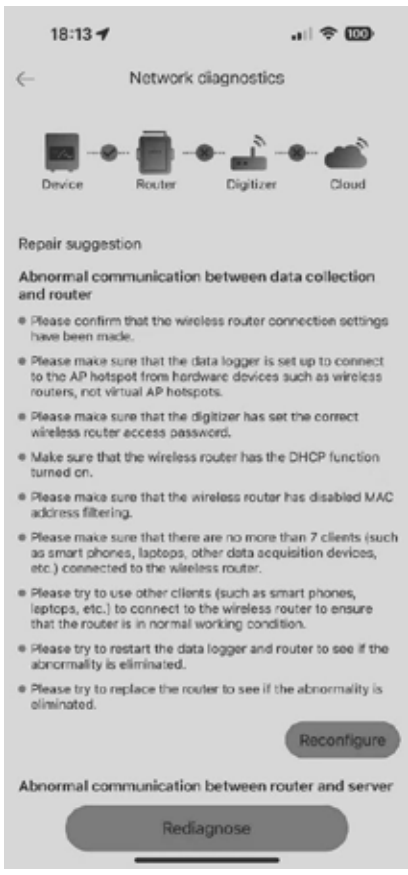

| The configuration is successfully | The configuration failed |
|--------------------------------------------------------------------------------------------------------------------------------------------------------|----------------------------------------------------------------------------------------------------------------------------------------------------------------------------------------------------------|
| <p>Green lines between device, data logger, router, and server.</p>  | <p>Red crosses between device, data logger, router, and server. Please refer to APP instructions to reconfigure.</p>  |

- After Bluetooth configuration, please **disconnect** the Wi-Fi module of the Bluetooth connection on the smartphone to avoid automatic connection and unable to access the network. The login page will prompt "Server not found".

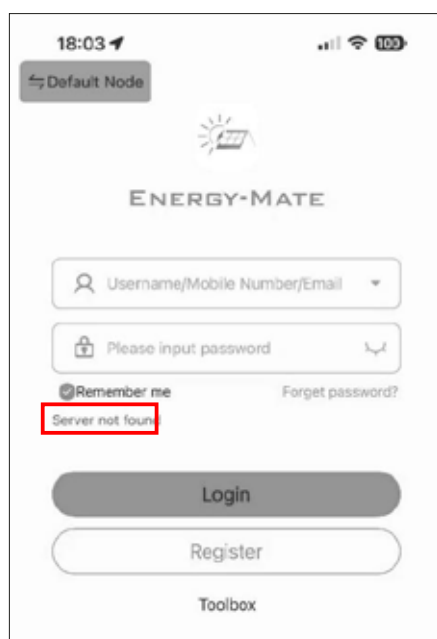

2-3 Registration and login

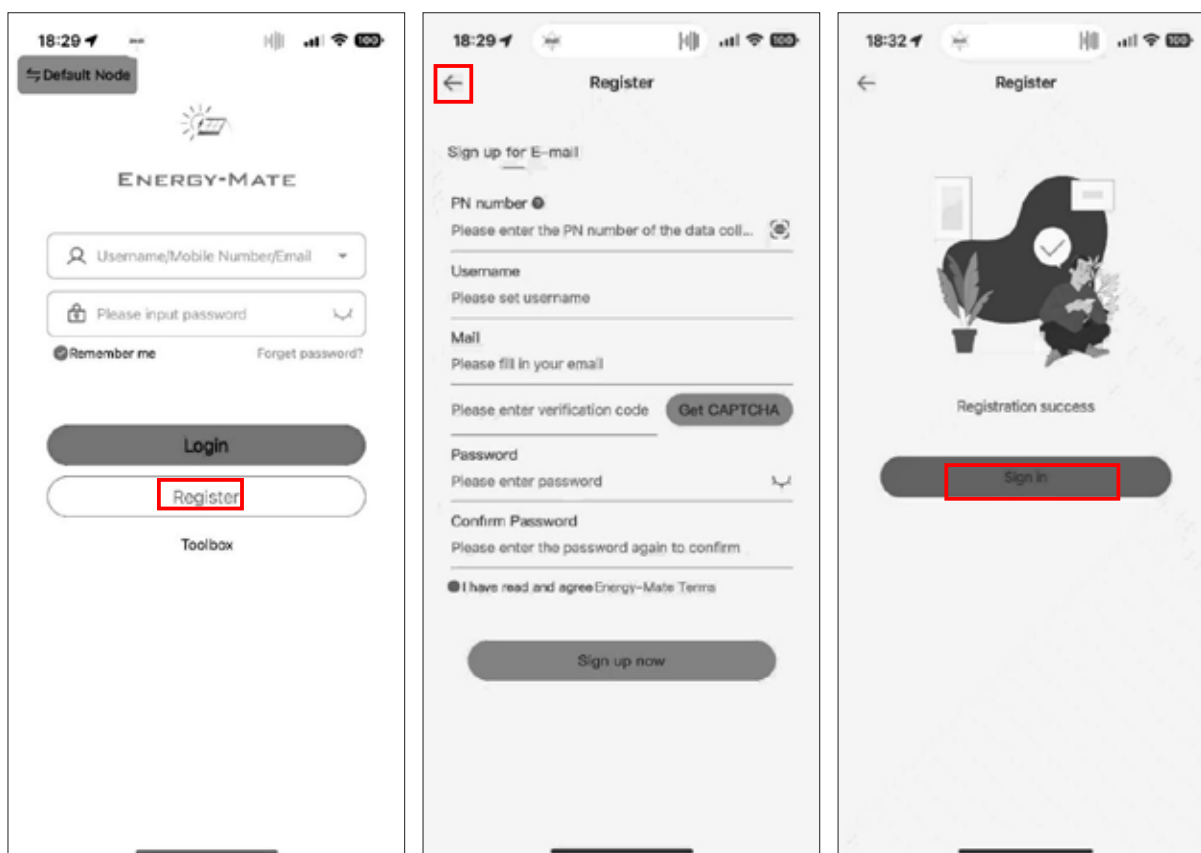

- Connect your smart phone to the router.
- Registration at first time.
- Click the "Register" to enter registration page and fill in the information. Once registration is complete, click "Sign in" or click  to return to the home page. Then, enter the registered username and password to log in.



2-4 Datalogger

- After login, the default Home page will appear.
- Choose Datalogger page to see the Wi-Fi module list.
 - ◆ Gray icon means Wi-Fi module is offline. Please refer to 2-2 Initial Setup to choose local Wi-Fi or Bluetooth configure Wi-Fi module network.
 - ◆ Green icon means Wi-Fi module is online.



- Click  to see the Wi-Fi module information.
- Click  to rename device, data debugging, restart the datalogger, and delete datalogger.
 - ◆ Rename device: rename the Wi-Fi module name.
 - ◆ Data debugging: send RS232 commands to the inverter in hexadecimal format.
 - ◆ Restart the datalogger: restart the Wi-Fi module.
 - ◆ Delete datalogger: delete the Wi-Fi module. The inverter information in the device page will **also be deleted**. Once deleted, you **can** add datalogger under another account.

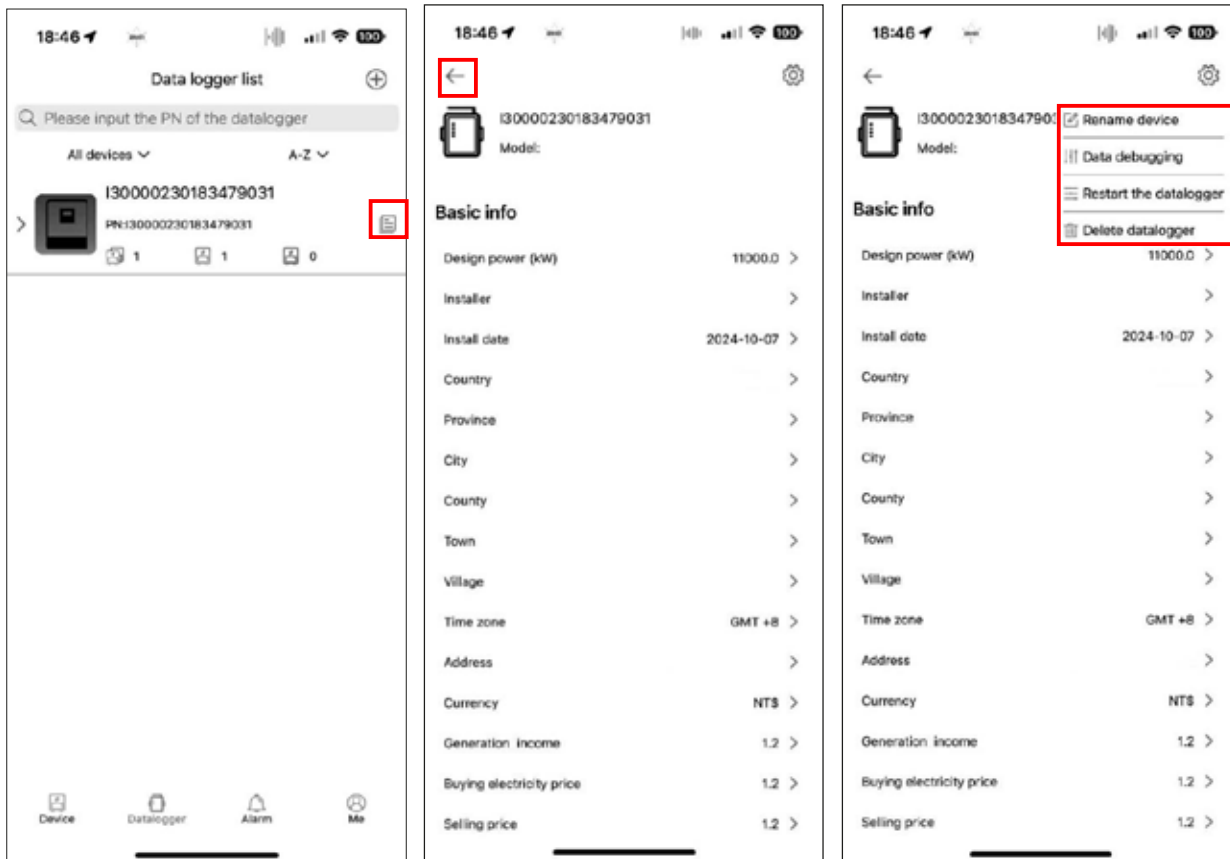

2-5 Device

- Choose Device page to see the inverter list.
 - ◆ Gray icon means inverter is offline.
 - ◆ Green icon means inverter is online and no warnings and faults.
 - ◆ Yellow icon means inverter is online and has a warning.
 - ◆ Red icon means inverter is online and has a fault.

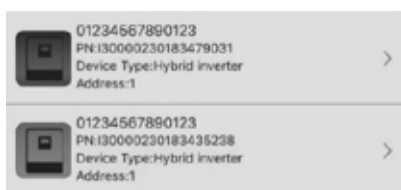

- Click to see the inverter information.
- Click to rename device and delete device.
 - ◆ Rename device: rename the inverter name.
 - ◆ Delete device: delete the inverter. The Wi-Fi module information in the datalogger page will **not be deleted**. Even if deleted, you **cannot** add Wi-Fi module under another account.

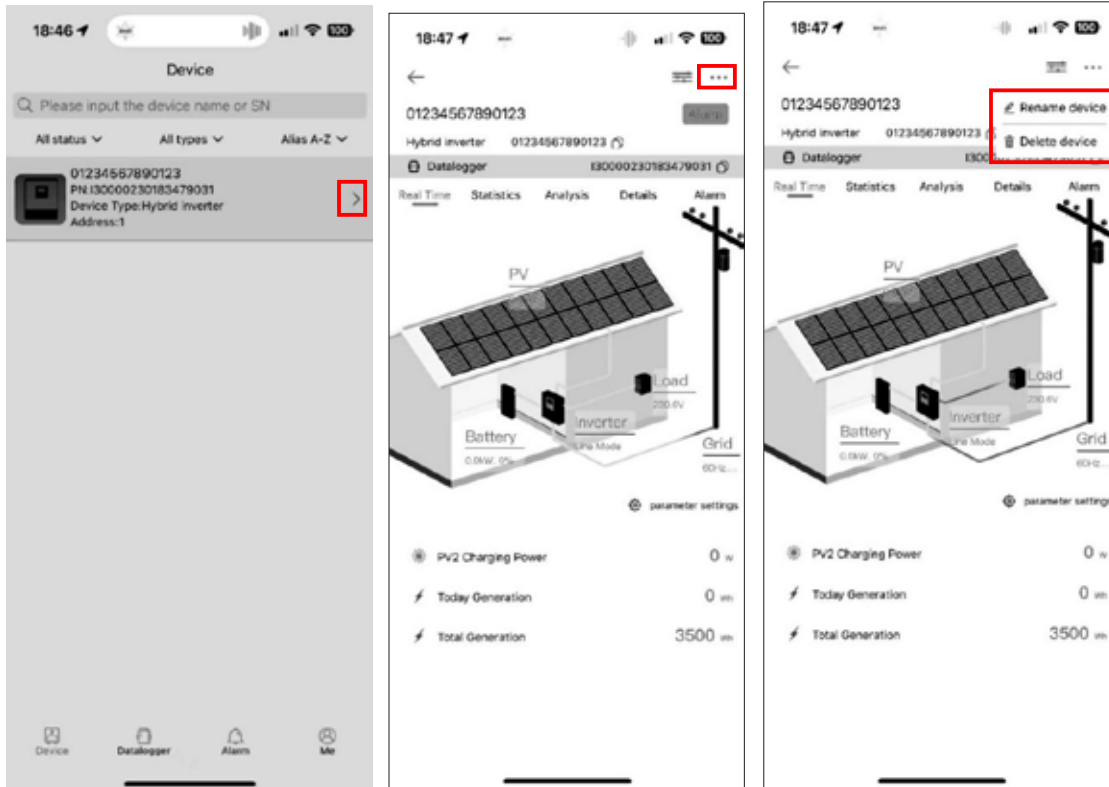

- Click to enter setting parameters page. The setting items on the parameter page will be different based on different models.

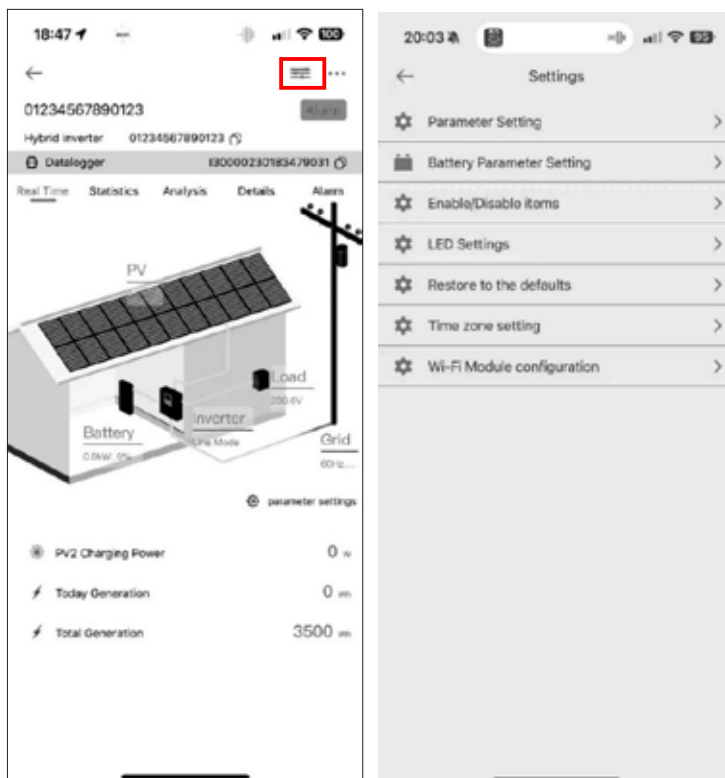

- Click "Real Time" to see the inverter real-time data. Click "parameter settings" to choose data you want to see on the real time page. You can choose up to **10 data**.

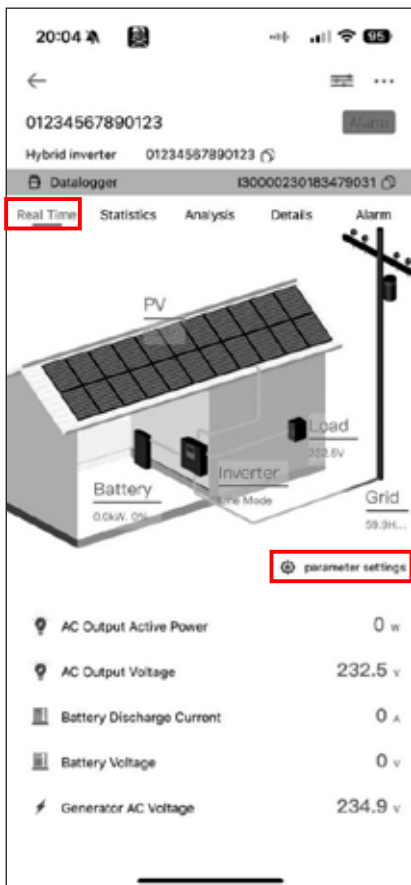

- Click "Statistics" to see the inverter solar power per hour, day, month and year.
 - Day: Click the button to query the hourly power generation data of the current day.
 - Month: Click the button to query the daily power generation data of the current month.
 - Year: Click the button to query the monthly power generation data of the current year.
 - Total: Click the button to query the annual power generation data.

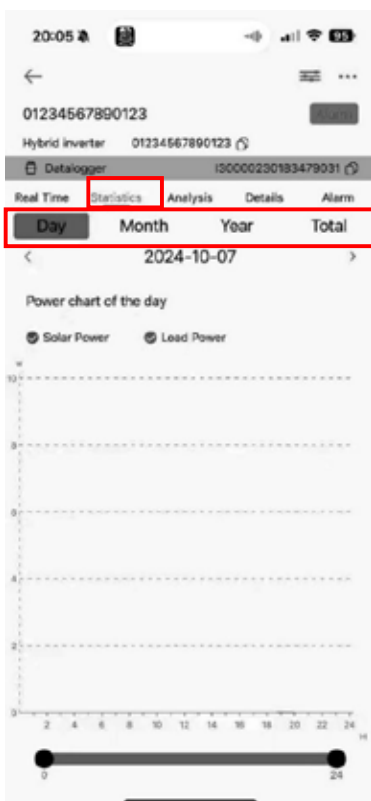

- Click "Analysis" to see the inverter data per hour. Click "SelectedXTerm" to choose the data you want to compare. You can choose up to **2 different units** such as energy (kWh) and current (A).

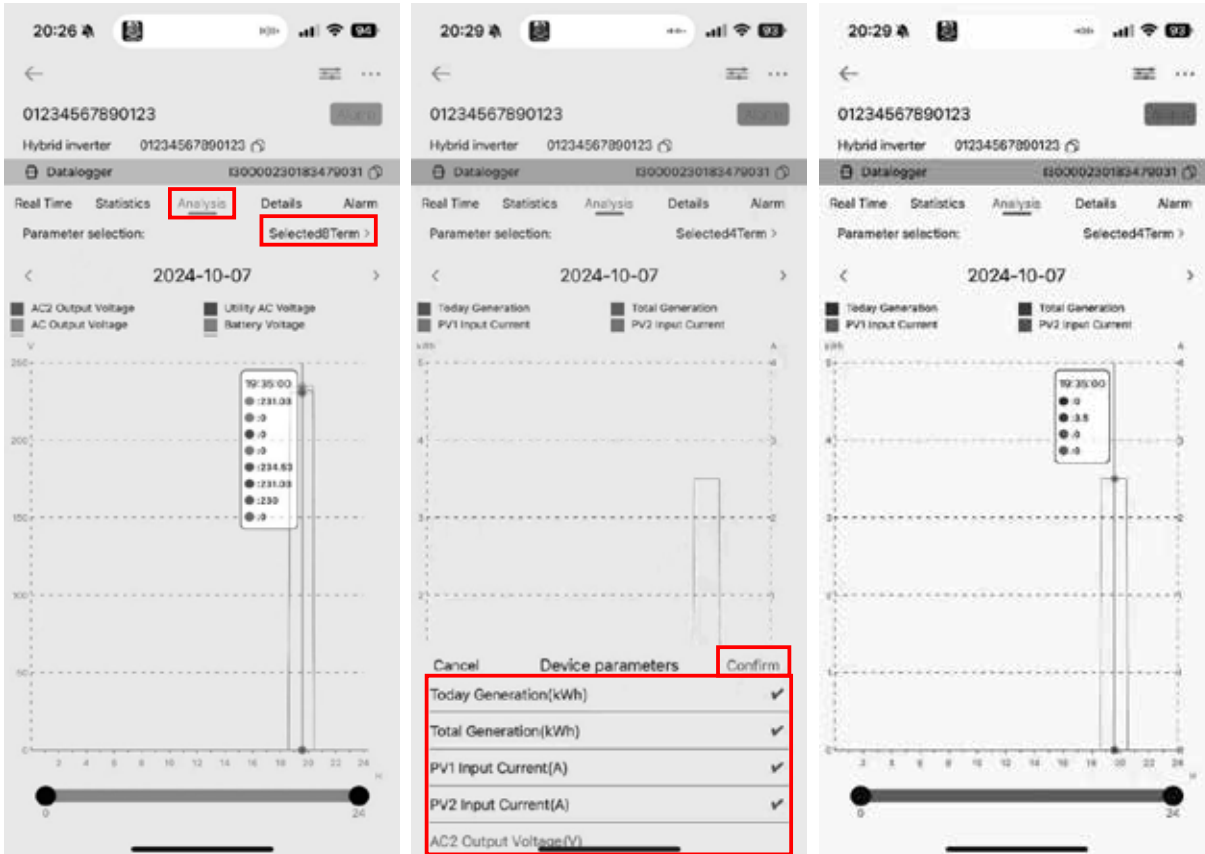

- Click "Details" to see the inverter history.

| Timestamp | Data name | Data |
|-----------|---------------------------|----------------|
| 20:02:03 | SN | 01234567890123 |
| | Main CPU | 0000191 |
| 19:57:14 | Firmware Version | |
| 19:52:24 | Secondary CPU | 0009703 |
| 19:52:24 | Firmware Version | |
| 19:47:34 | Input Relay | 64.01 |
| | CPU Version | |
| 19:42:44 | Utility AC Voltage | 0.0V |
| 19:26:33 | Utility AC Frequency | 0.0Hz |
| | Generator AC Voltage | 234.9V |
| 19:20:43 | Generator | |
| | AC Frequency | 50.9Hz |
| 19:15:53 | PV1 Input Voltage | 0.0V |
| 19:11:03 | PV2 Input Voltage | 0.0V |
| 19:06:13 | PV1 Charging Power | 0W |
| 19:01:23 | PV2 Charging Power | 0W |
| | Battery Voltage | 0.0V |
| 18:56:34 | Battery Capacity | 0% |
| 18:51:44 | Battery Charging Current | 0A |
| 18:46:54 | Battery Discharge Current | 0A |
| 18:45:55 | AC Output voltage | 232.5V |
| | AC Output Frequency | 50.9Hz |
| | AC Output Apparent Power | 0VA |
| | AC Output Active Power | 0W |
| | Output Load Percent | 0% |
| | Grid Mating Voltage | 230.0V |

- Click "Alarm" to see the inverter warning and fault.

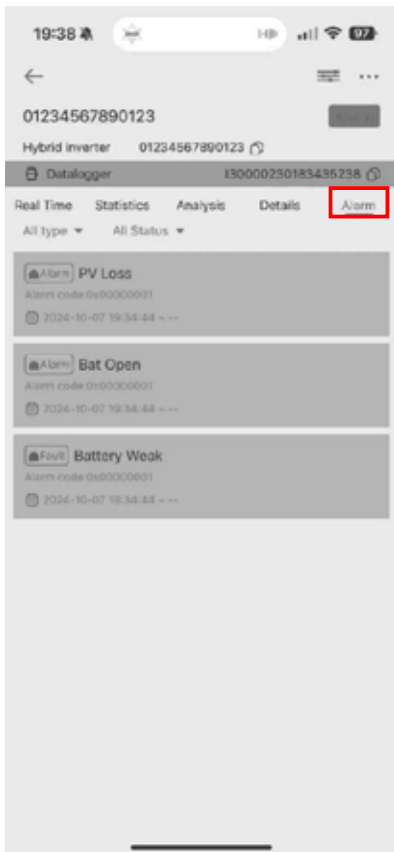

2-6 Alarm

- Choose Alarm page to see the warning and fault list of all inverters.



2-7 Me

- Choose Me page to see account information and app version.
- Click "Username" to modify nick name and password, and check if the mail has been bound. If the mail is bound, you can retrieve password through mail.