







# USER MANUAL

90-360KW DC EV Charger

<b>1. Safety Instructions</b> .....	1
<b>2. Technical Specifications</b> .....	1
<b>3. Introduction</b> .....	
3.1. Product Overview .....	2
	2
<b>4. Packaging</b> .....	3
4.1. Packaging .....	3
4.2. Transport .....	3
	4
<b>5. Installation</b> .....	4
5.1. Pre-Installation .....	5
5.2. Cable Reach .....	6
5.3. Construct Foundation .....	7
5.4. Standard Wiring .....	7
5.5. Dimensioned Drawing .....	7
5.6. Space Requirement .....	
5.7. Installation Steps .....	7
5.8. Parallel CAN Communication Wiring Instructions .....	7
	7
<b>6. Charging Process</b> .....	8
6.1. Operation Interface.....	
6.2. LED Operation.....	
6.3. Precautions.....	
6.4. EPO Operation.....	
	8
<b>7. System Configuration</b> .....	15
7.1. Wired Network Settings.....	
7.2. Intranet Settings.....	
7.3. Cellular Network Settings.....	
7.4. OCPP Connection.....	
7.5. Check Module Settings.....	
<b>8. Routine Maintenance</b> .....	16
<b>9. Trouble Shooting</b> .....	16

-  **WARNING:** It is forbidden to insert and unplug the plug during the charging process to ensure the safety of life and the vehicle during the charging process.
-  **WARNING:** It is strictly prohibited to continue to use this product for charging in case of failure.
-  **WARNING:** Obvious maintenance marks shall be set up. Isolation and protection measures shall be added to live parts that may be near by operators to avoid contact.

## CAUTIONS

-  **CAUTION:** Wrong installation and testing of the charger will cause potential damage to the vehicle battery, assembly, and the charger itself.
-  **CAUTION:** To reduce the risk of fire, connect only to a circuit provided with 100 amperes maximum branch circuit overcurrent protection in accordance with the National Electrical Code, ANSI/NFPA 70 and the Canadian Electrical Code, Part I, C22.1
-  **CAUTION:** Do not operate the charger in temperatures outside its operating range of 35°C to + 55°

Electrical equipment should only be installed, operated, serviced, and maintained by qualified personnel. No responsibility is assumed by our company for any consequences arising out of the use of this material. A qualified person is one who has skills and knowledge related to the construction, installation, and operation of electrical equipment and has received safety training to recognize and avoid the hazards involved.

If the machine line drawing in the manual is different from the actual product, do not worry, because the reference picture is the same as the installation method of the actual product.

## 2. Technical Specifications

MODEL	MF-DC-EV90KW	MF-DC-EV120KW	MF-DC-EV180KW	MF-DC-EV240KW	MF-DC-EV300KW	MF-DC-EV360KW
Charging Type	DC fast charging					
Outlet Options	T2: AC Type 2 C: CCS2 cable, A: CCS1 cable, J: CHAdeMO cable, G: GBT cable					
AC Input Power (380VAC)	138A, 96 kVA	192 A, 128 kVA	288A, 192 kVA	384A, 256kVA	484 A, 320kVA	582A, 384kVA
Input Voltage Range	380/400/415 VAC					
Input Frequency	50 Hz or 60 Hz					

DC Outlet	DC Output Power Rating	90kW	120kW	180 kW	240 kW	300 kW	360kW
	DC Output Voltage	200-1000 Vdc (Constant power from 300-1000 Vdc)					
	Number of EV Served	Up to 2 (C, A, G, CC, AA, JC, JA, GG models)					
	Cable Length	5 m default, optional 6.0 m/ 7.0 m					
	Maximum Current*	CCS Cables	200 A ( Adapts to 300A )			300 A ( Adapts to 500A )	
CHAdeMO Cables		125 A					
GBT Cables		200A		250A			
Electro-Magnetic Compatibility	Class A						
Network Type	TN-S, TN-C, TN-C-S, TT (required external RCD)						
Connector Type	3P + N + PE						
Protection	Overcurrent, overvoltage, undervoltage, integrated surge protection, grounding fault including DC leakage protection, door opening protection						
Overvoltage Category	Type II						
Power Factor (Full Load)	≥ 0.99						
THDi	≤ 5%						
Efficiency	≥ 93% (peak)		≥ 94% (peak)				
Standby Power	< 35W						
Short Circuit Current	10 kA						
Pre-charge Current	< 1 A						
Inrush Current	< 100 A						
Leakage Current	0.8 mA						
Energy Metering	Standard: Meter for DC outlet, Optional: AC inlet						
Cellular Communication	GSM, 4G, LTE						

## 1. Safety Instructions

Read and follow the instructions and warnings in this manual before attempting to install this product. Keep this manual for future reference.

Please follow the below safety precautions to prevent bodily injuries and property damages.

### INSTRUCTIONS RELATING TO RISK OF FIRE OR ELECTRIC SHOCK



**WARNING:** When the product is running, it should pay attention to ventilation, heat dissipation and keep the environment clean. Avoid installation in places with frequent occurrence of storm, rainstorm, lightning and other severe weather.



**WARNING:** During installation, if any abnormal phenomena such as cracking, loose case lock, water leakage are showing up, all operations shall be stopped immediately and professionals shall be informed in time to deal with them.



**WARNING:** Do not put inflammable, explosive or combustible materials, chemicals, combustible steam and other dangerous goods near the charger.



**WARNING:** If any leakage or insulation failure occurs during the operation of the product, please press the emergency power off button immediately.



**WARNING:** In case of rain and thunder, please use electricity carefully. It is better to stop charging.

### WARNINGS



**WARNING:** This device should be supervised when used around children.



**WARNING:** Do not put fingers into the electric vehicle connector.



**WARNING:** Do not use this product if the flexible power cord or EV cable is frayed, has broken insulation, or any other signs of damage.



**WARNING:** Do not use this product if the enclosure or the EV connector is broken, cracked, open, or shows any other indication of damage.



**WARNING:** Please keep the nozzle clean and dry. If there is any dirt, please wipe it with a clean, dry cloth. It is strictly prohibited to touch the charging core with hands when it is powered.



**WARNING:** Do not attempt to disassemble, repair or modify the charger. For repairs or modifications, please contact the staff. Improper operation may result in damage, water leakage, electricity leakage, etc.

User Authentication	RFID, QR code					
User Interface	15" LCD high -contrast touchscreen					
Communication Protocols	Proprietary and OCPP 1.6J					
RFID Reader	ISO/IEC 14443 A Mifare RFID reader					
Emergency Button	Yes					
<b>CONFIGURATION</b>						
Software Upgrade	Yes					
Language System	English, Chinese, French, Spanish					
<b>GENERAL CHARACTERISTICS</b>						
Protection Rating	IP54 and IK10 (cabinet) / IK8 (touchscreen)					
Housing Material	SUS430					
Operating Altitude	Up to 2000 m					
Operating Temperature	-35 °C to 55 °C					
Storage Temperature	-40 °C to 70 °C					
Humidity	< 95%, non-condensing					
Mounting	Free-standing cabinet					
Dimensions (D x W x H) mm	640 x 750 x 1650					
Net Weight (kgs)	297	315	345	375	449	524
<b>COMPLIANCE STANDARDS</b>						
Codes & Standards	IEC 61851- 21 -2, IEC 61000, IEC/EN 61851-1, IEC 61851-23, IEC 61851-24, IEC 62196-1, IEC 62196-3, GBT18487, GBT20234, NB/T 33008.1, NB/T 33001, CNS15511					
Communication to the EV	DIN 70121, ISO/IEC 15118, CHAdeMO 1.6J, GBT27930, GBT 34657, GBT 34658					

\* Product specifications are subject to change without further notice.

### 3. Introduction

The DC EV charger comes with two nozzle. The maximum output power of 360kw, and the efficiency is not less than 94%. For ease of operation, the electric car charger is equipped with a 15-inch industrial touch screen, a standard Ethernet connection, and an embedded RFID reader with WI-FI features to communicate with LAN routers, vehicles, and action devices, and other chargers.

### 3.1. PRODUCT OVERVIEW

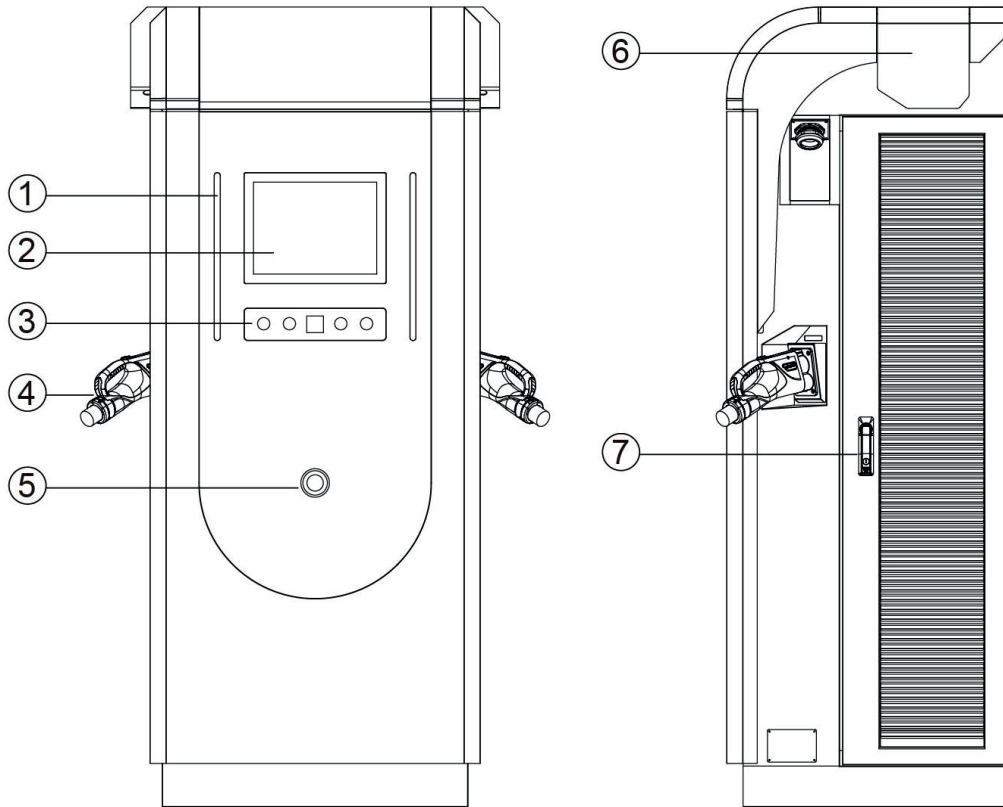

- |                            |                          |                               |
|----------------------------|--------------------------|-------------------------------|
| 1. SOC Charge Status Light | 2. Touch screen          | 3. Operation indication panel |
| 4. Nozzle                  | 5. Emergency stop button | 6. labor-saving device        |
| 7. Gate lock               |                          |                               |

## 4. Introduction

### 4.1. PACKAGING

The charger is delivered in a specialized wood packaging. The following figure shows the packaging for the charger.



## 4.2 TRANSPORT

Move the charger to the required installation location with a forklift truck. Please move the charger with the utmost caution!



**NOTE:** The Charger must be stored in its original packaging in a dry environment from  $-40^{\circ}\text{C}$  to  $70^{\circ}\text{C}$ . It is recommended to transport the Charger to its final destination in its original packaging and unpack it there.

## 5. Installation

### 5.1. PRE-INSTALLATION



- Danger to life due to improper installation!
- Ignoring environmental conditions when handling electricity can lead to hazardous situations.

Before performing any installation activities, carefully read each item listed in this chapter that is critical to the installation process.

#### [Location Selection]

**Consider before choosing where to install:**

1. Meets all criteria regarding charger placement and location.
2. Make sure the installation location complies with cellular signal strength standards.
3. Avoid use in offshore environments or land-based outdoor environments near strong pollution sources and in environments with simple shelter. Otherwise, it is easy to lead to corrosion of the product, water ingress and other problems caused by module failure, resulting in abnormal functions or component damage is not covered by the warranty. A source of contamination is defined as an area within the following radius:
  - A. 0.5 km away from salt water (e.g. ocean).
  - B. 3 km away from heavy pollution sources such as metallurgy, coal mines, and thermal power plants.
  - C. 2 km away from medium pollution sources such as chemical, rubber, electroplating, etc.
  - D. 1 km away from light pollution sources such as food, leather, heating pots, etc.

4. For offshore applications, there may be pitted rust of the module shell or shortened life of the whole machine, which needs to be carefully selected, please consult the relevant service department for details. The offshore range value is within the following radius: 0.5 km ~ 3.7 km from salt water (such as ocean).
5. The installation environment shall meet the environmental characteristics specified in the technical data.

### [Location Selection]

1. Area is dry and well ventilated.
2. The area is not exposed to dust, high temperatures, explosive gases, flammable materials or corrosive fumes.
3. Wiring and conduit needed to connect the charger to the board.
4. The location of the charging port when the vehicle is parked.
5. Space clearance requires minimum dimensions for airflow and service channels.

### 5.2. CABLE REACH

In the default configuration, the Charger comes with a cable length of 500cm. Figure 5.2 below shows the Charger's operating radius (5m).

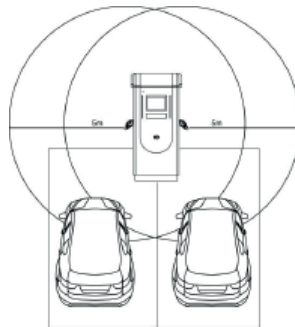
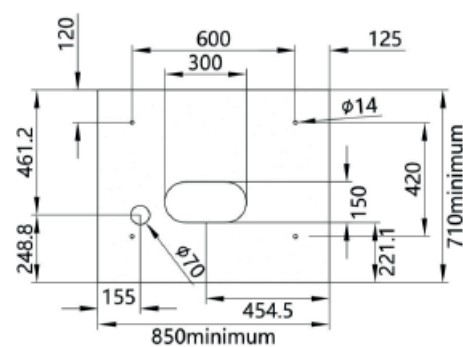

Figure 5.2

### 5.3. CONSTRUCT FOUNDATION

- The charger can be built on a concrete foundation, the flat surface of foundation should not be less than the dimension of 850 mm \* 710 mm.
- When preparing the concrete base and cabling pay regard to positions of cable through holes and expansion bolts, which was dimensioned in Figure 5.3.1.

**NOTICE:** The reserved bolts for concrete base must be exposed at least 56mm.



FRONT

Figure 5.3.1

The height of the foundation is determined by the topography and natural environment of the site. Depending on rainfall and drainage, a height of between 15 cm and 30 cm above the ground is recommended. The foundation must be about 80 cm deep in the ground due to frost protection.

**NOTE:**

- The unit must be mounted on solid and flat base.
- Different types of bases require the use of expansion bolts, or choose suitable screw installation, in some conditions require drilling.
- The laying of power cables shall be in accordance with relevant national and industrial standards, specifications.
- Cable selection specification shall be selected according to the number of equipment and the type, power, voltage and current level of the equipment installed.
- When cables are laid, they are strictly forbidden to be exposed.
- When the cable is buried directly, the buried depth should not be less than 0.8m in order to prevent freezing.
- The selection of power cable specifications should be selected according to the installation environment and fire requirements.

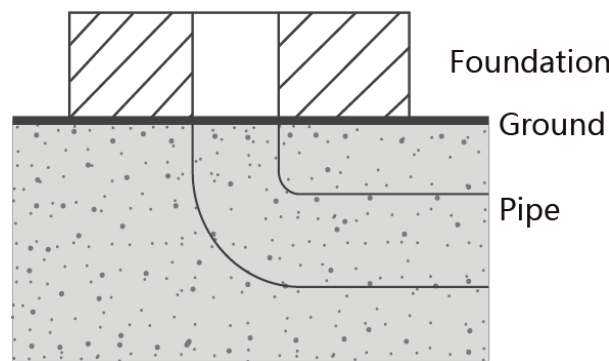

**Figure 5.3.2**

**5.4. STANDARD WIRING**

- To connect the charger to the electrical panel, a professional installer or qualified electrician should consider the following guidelines and consult the table below.
- Overview of parameters for dimensioning of the protective devices and power supply line

Charger rating	90kW	120kW	180kW	240kW	300kW	360kW
Input phases (mm <sup>2</sup> )	70	95	150	240	≥150*2	≥190*2
Input Neutral (mm <sup>2</sup> )	50	50	95	150	501	190

Input PE(mm <sup>2</sup> )	35	50	95	150	150	190
Breaker With RCD Type A Breaker 3Pole (A)	200	250	400	500	630	800
Circuit breaker (A)	200	250	400	500	630	800

- Specification requirements for fixing bolts

Charger rating	90kW	120kW	180kW	240kW	300kW	360kW
Input Phases terminal block	M12	M12	M12	M12	M12	M12
Input Neutral terminal block	M8	M8	M8	M8	M8	M8
Input PE terminal block	M8	M8	M8	M8	M8	M8

The Cable sizes is based on table B.52.12 of IEC 60364-5-52 with the following assertions:

- 90 °C conductors
- An ambient temperature of 30 °C
- Use of copper conductors
- Installation method F

PE cable size is based on table 54.2 of IEC 60364-4-54.

If the ambient temperature is greater than 30 °C, larger conductors are to be selected in accordance with the correction factors of the IEC.

**Standard wiring considerations:**

- Certified Type A RCD should be installed upstream close to the charger.
- In accordance with the electrical installation standard IEC60364-7-722. Refer to local regulation.
- The circuit breakers and the power cable minimal cross-sections are overvalued to ensure the functionality of the charger with higher temperatures.

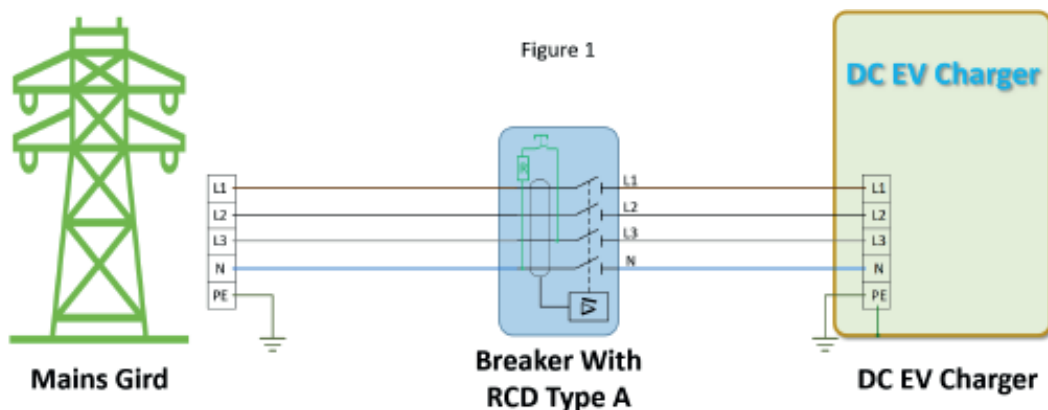

The power losses on the power supply line must be less than +/-10 % of the rated power in accordance with IEC 60038 and local standards. For this reason, the cable sections or line length must be reassessed by a professional electrician in accordance with maximum power loss regulations. Also, when dimensioning the power supply line, observe the possible reduction factors and the increased environmental temperatures inside the connection area of the charger (see temperature rating of the supply terminals). Under certain circumstances, this can increase the cable cross-section and change the temperature resistance of the power supply line.

**Number Description:**

- 1. DC Charger
- 2. Residual Current Device (RCD)
- 3. Circuit breaker

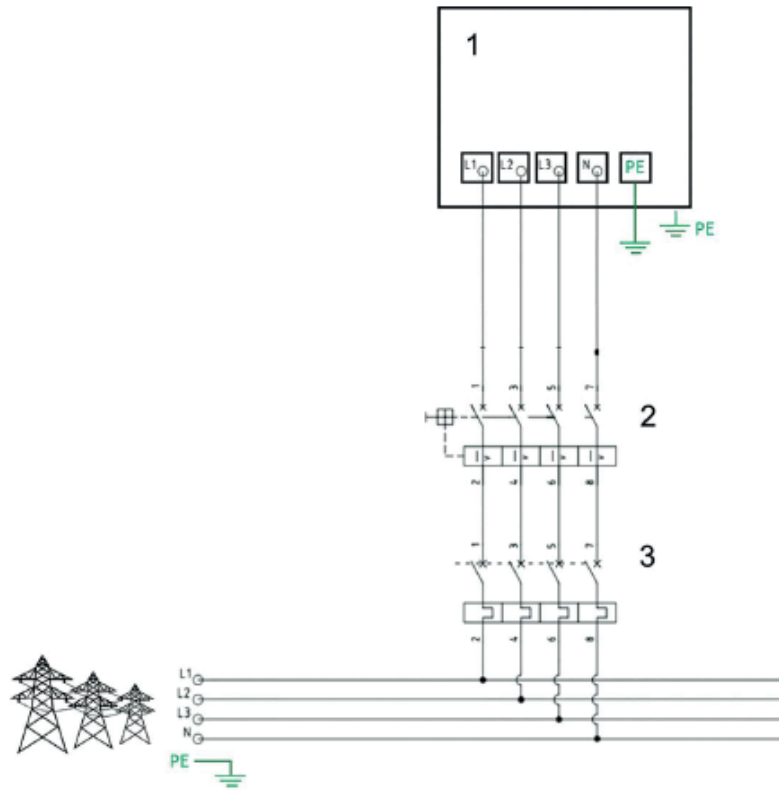

**5.5. DIMENSIONED DRAWING**

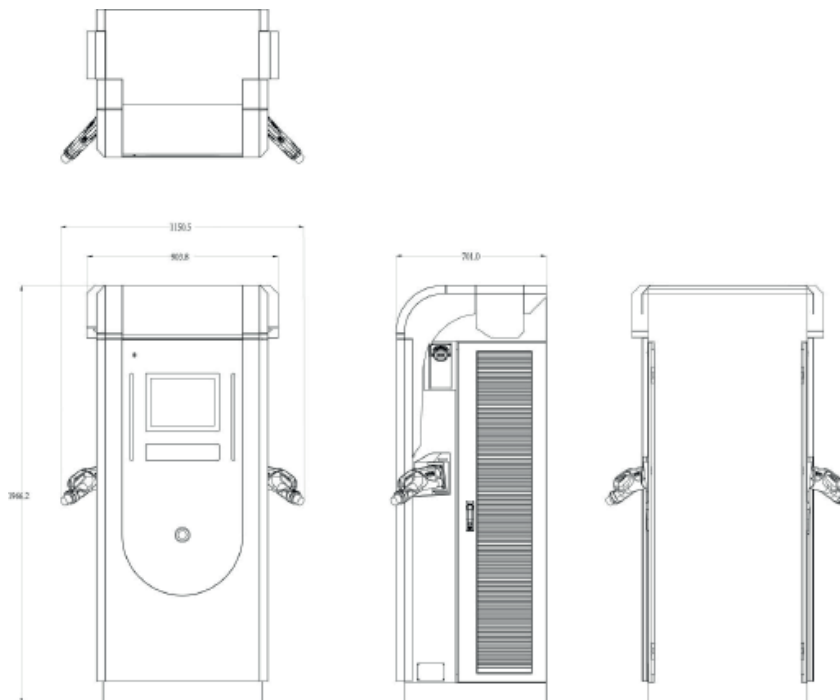

## 5.6. SPACE REQUIREMENT

When installing the charger, make sure to keep a minimum distance from objects that may be around the charger to allow for adequate airflow, and secondly, to leave room for possible repair or operations.

The following diagram shows the recommended minimum distances during on-site installation:

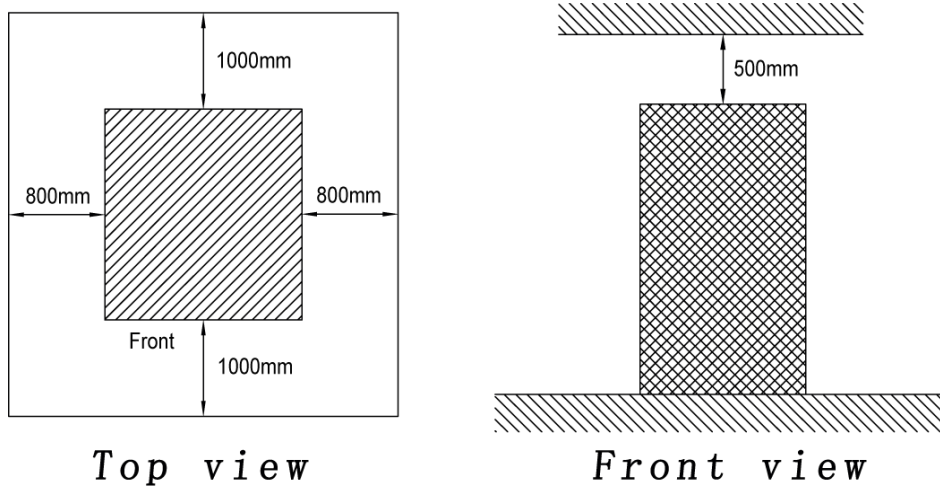

Figure 5.6

**NOTE:** Clearance dimensions are published for airflow and service access only. Consult your local safety regulations and standards for other requirements in your local area.

## 5.7. INSTALLATION STEPS

### Step 1: Mark the installation location on the concrete base

Use installation template and level tool to mark the mounting position and apply the double-screw bolts

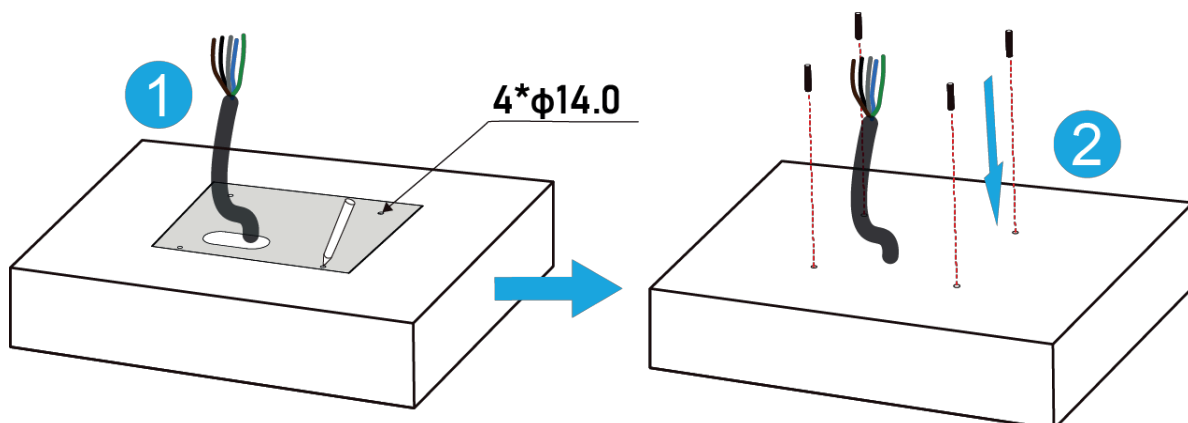

**Step 2: Demolition of steel belt box and foam**

Break all the tongues straight and remove the band box and foam.

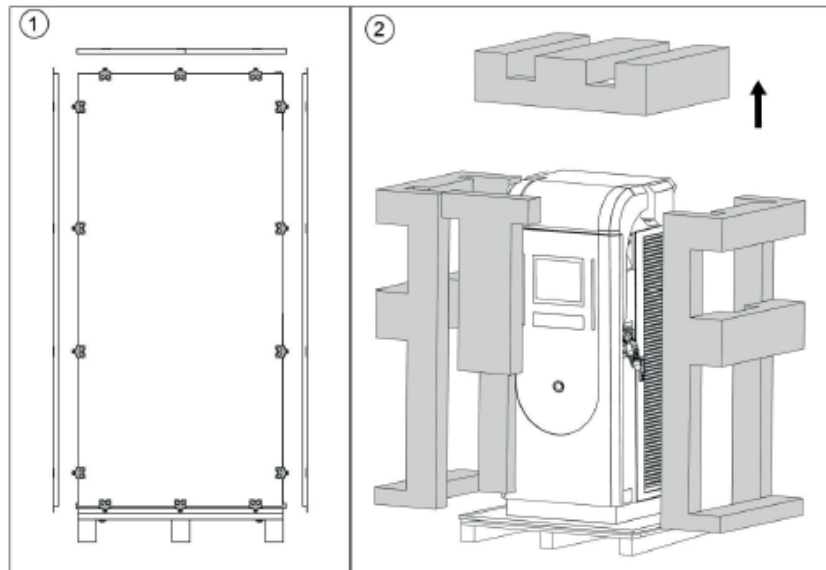
**Step 3: Remove the top four ring hole screws**

Remove the top four ring hole screws (M12)

**Step 4: Fix the lifting rings on the screw hole**

Fix the lifting rings (M12) on the screw hole

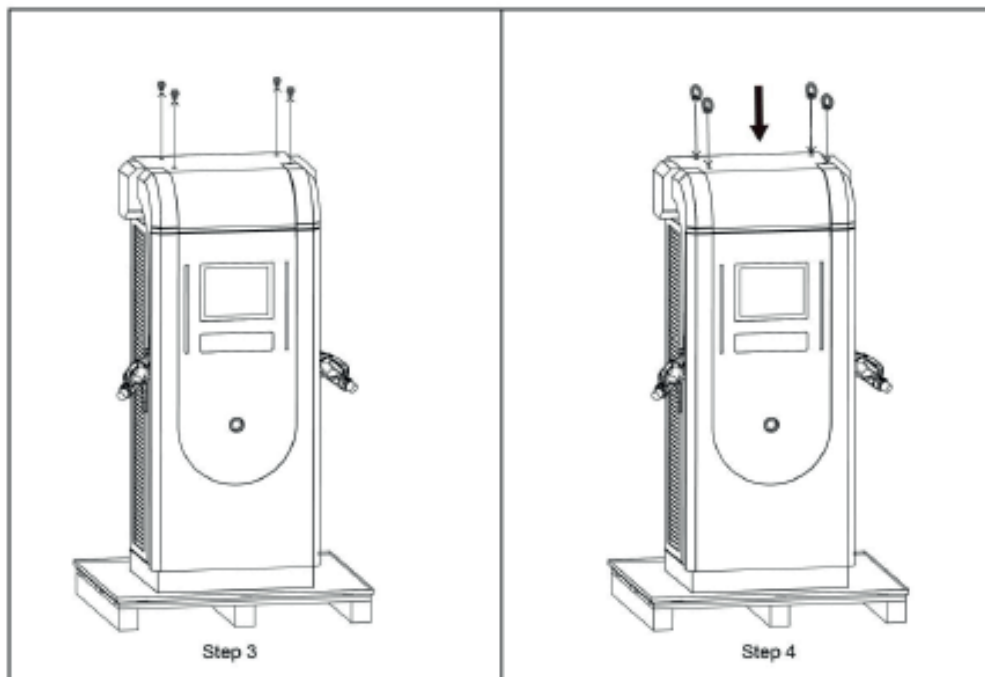

**Step 5: Remove the fixing screws between the chassis and the base**

1. Open the front, left and right shutters.
2. Remove the fixing screws (M12) between the chassis and the base

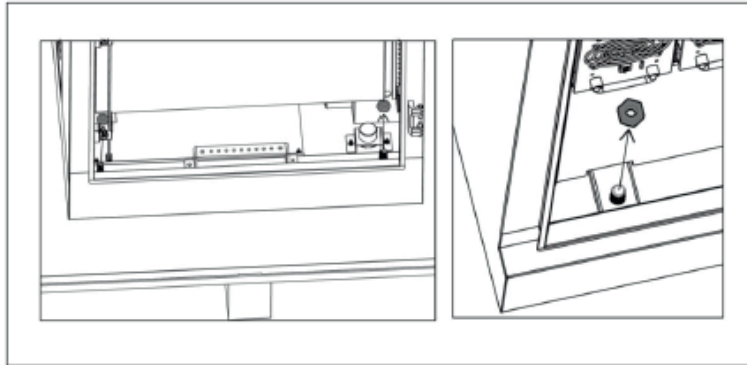
**Step 6: Lift the charger to the concrete base**

Close the front, left and right shutters, and then lift the chassis to the concrete base with steel wire ropes through lifting rings.

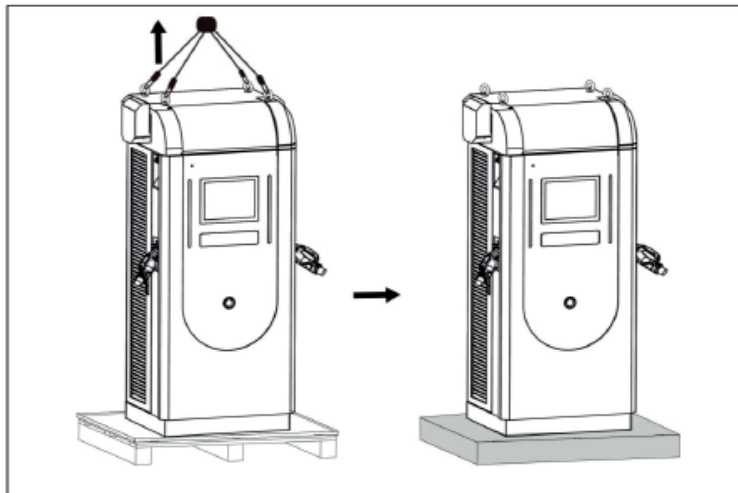
**Step 7: Attach the charger to concrete base**

Open the front, left and right shutters, then use screws (M12) to fix the charger on the concrete base.

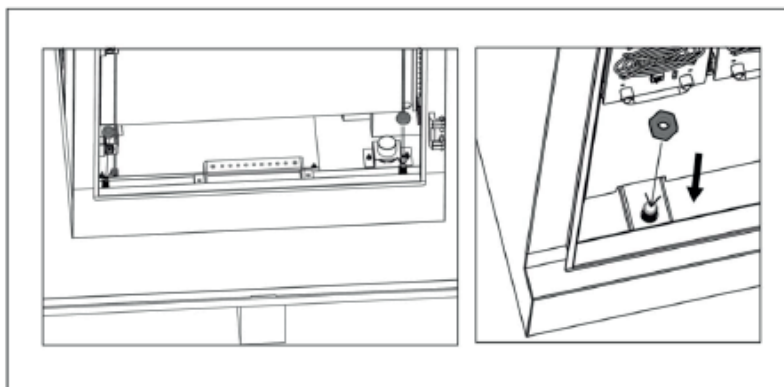

## Step 8: Connect the Charger

Install the L1, L2, L3, N, PE wires. Position the connection according to the following figure. (Take 360kw as an example, the wiring mode of other models is the same as 360kw)

Close the front door.

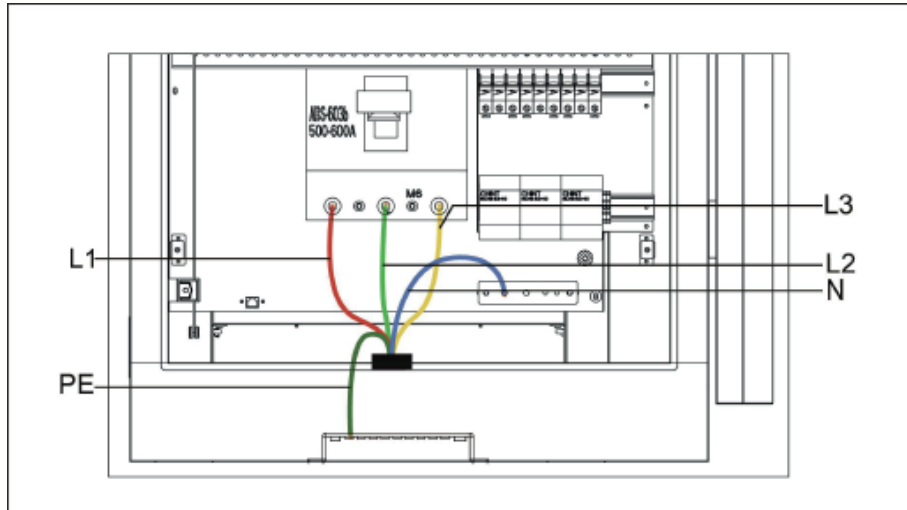

**NOTE:** Before charging the charger, recheck all electrical connections after all wiring is complete. After the charger is powered on, the LCD screen will display the status of the charger.

### 5.8. PARALLEL CAN COMMUNICATION WIRING INSTRUCTIONS

- Open the front door.
- Two charging stations are connected in parallel for communication, with the H line connected to the H line and the L line connected to the L line.

#### NOTE:

- CAN H and CANL should not be tied to the input lines.
- When the charging station is shipped, there will be an M3 accessory wiring.

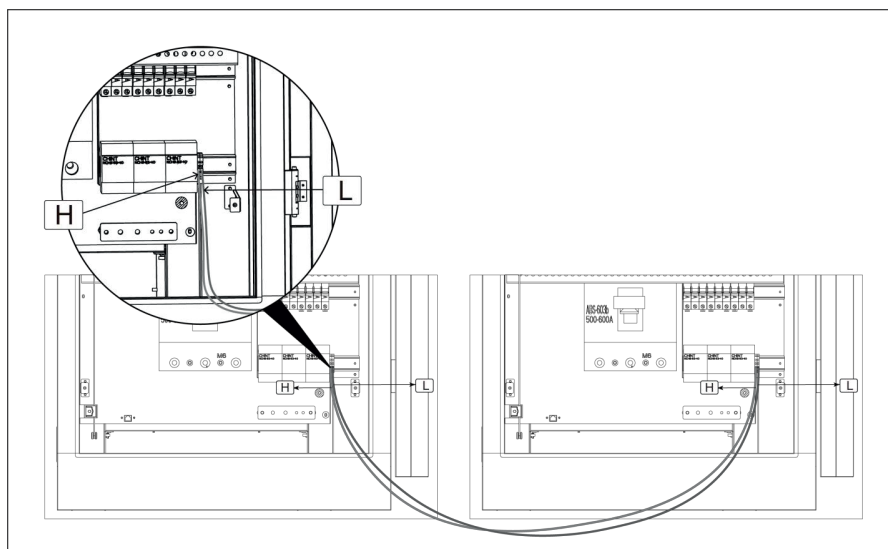

## 6. CHARGING PROCESS

### 6.1. OPERATION INTERFACE

#### 6.1.1. Display Menu Tree

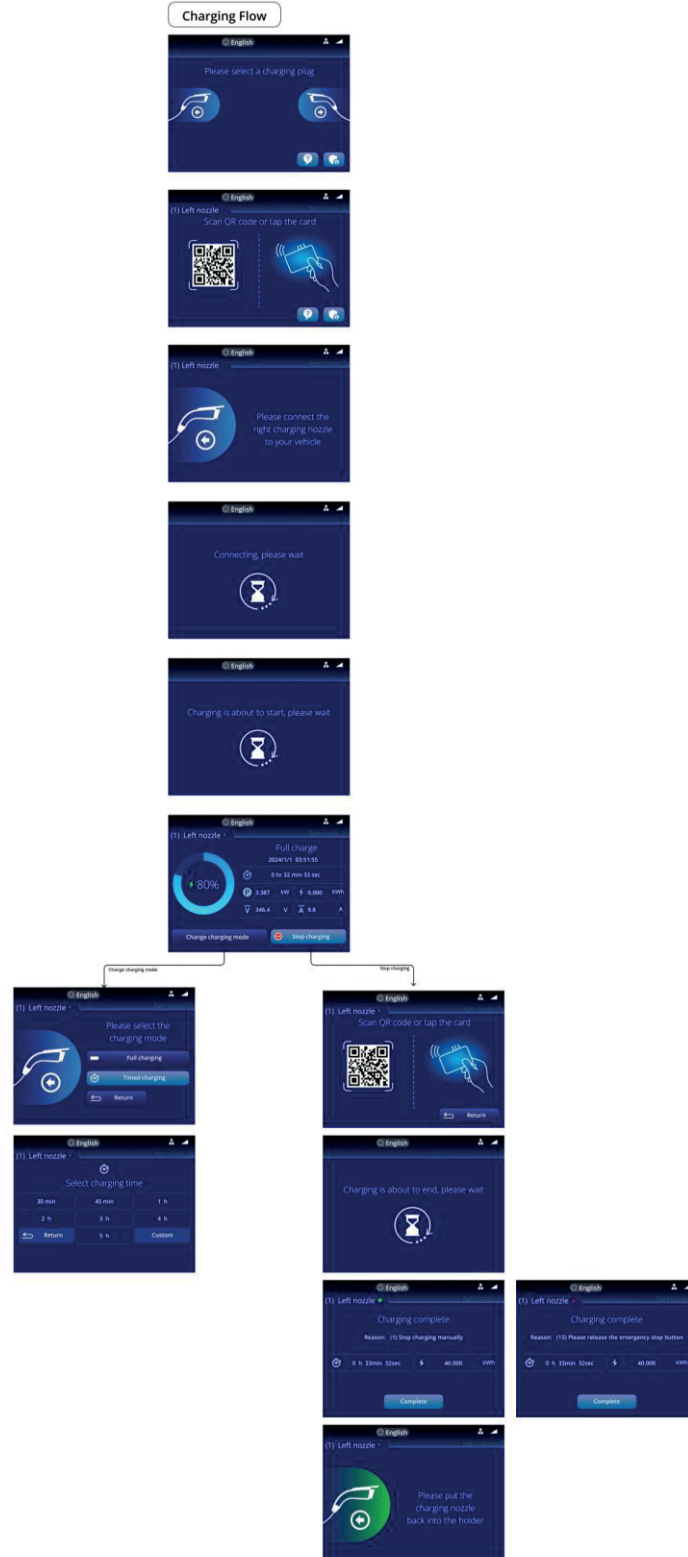





Settings & Records Flow

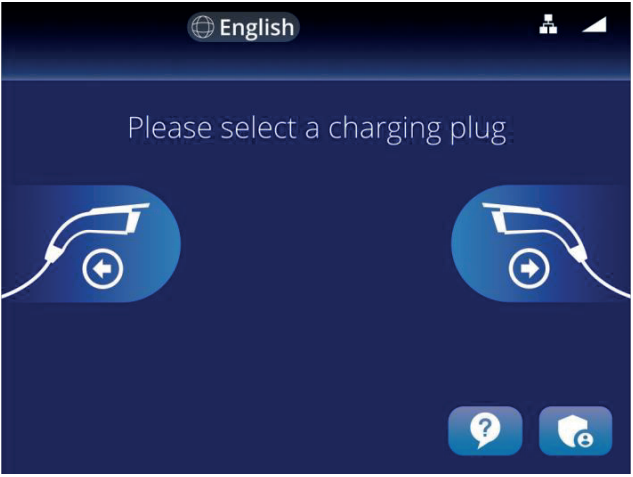

6.1.2. User Operation Steps

Operating steps	Operating interface
<p><b>Step 1:</b></p> <ul style="list-style-type: none"> <li>Select a nozzle on the screen</li> </ul>	 <p>The screenshot shows a dark blue interface with 'English' at the top left. The main text reads 'Please select a charging plug.' Below this are two circular icons, each containing a white charging nozzle and a plus sign. At the bottom right, there are two smaller icons: a question mark and a shield with an 'e'.</p>
<p><b>Step2-1:</b> Choose to scan QR code or swipe card. Connect the left charging gun to your vehicle</p>	 <p>The top screenshot shows the interface with 'English' at the top. It has two tabs: '(1) Left nozzle' and 'Right nozzle (2)'. The main text says 'Scan QR code or tap the card'. On the left is a QR code, and on the right is an illustration of a hand swiping a card. The bottom screenshot shows the same tabs, but the 'Left nozzle' tab is selected. The main text says 'Please connect the right charging nozzle to your vehicle'. On the left is a circular icon with a white charging nozzle and a left-pointing arrow.</p>

**Step 3:**

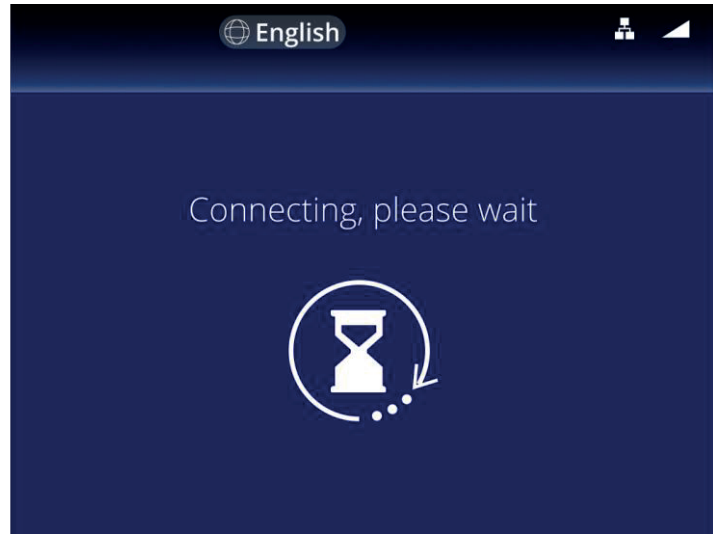

Once the authorization is complete, this charger will start charging.

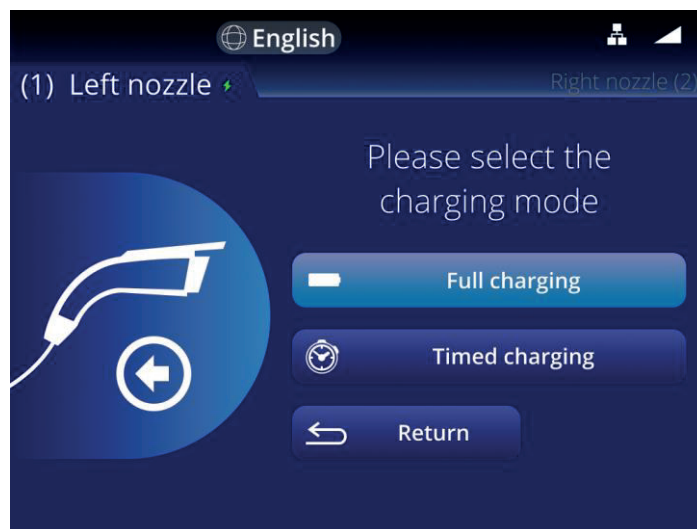

**Step 4:**

- While the vehicle is charging, charging data can be viewed on the LCD screen via the touchscreen.
- Tap change charging mode to select full charging or timed charging.

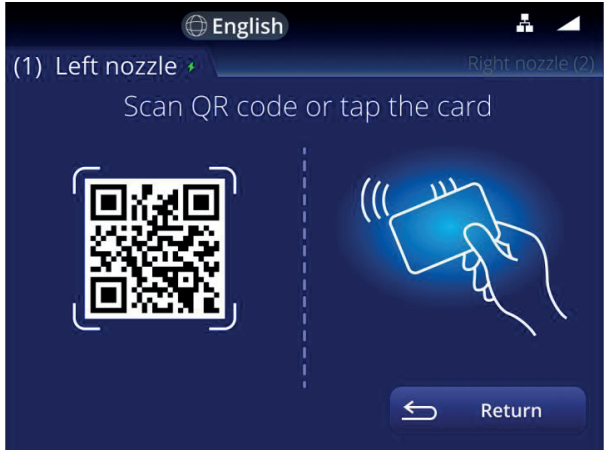

<p><b>Step 5:</b> After the charging is completed, it will pop up message to click the screen and select the settlement method.</p>	
<p><b>Step 6:</b> It will display the charging time and charging capacity as the final screen. When charging is complete, put the nozzle back in place.</p>	



**NOTE:**

During charging period, if it's necessary to stop charging, simply touch " icon on the right bottom corner.

**6.1.3. Charging Page Description**



- 1. Charging capacity of charged vehicle
- 2. Charging power
- 3. Charging voltage.
- 4. Change charge type
- 5. Charging time
- 6. Charging capacity
- 7. Charging current
- 8. Stop button
- 9. Language selection
- 10. Network status

**Figure 6-1 Real-time charging interface**

### 6.1.4. LCD Password Settings

Admin> Enter Password >Settings> Basic Settings>General information>Password

**NOTE: The initial password is 0000**

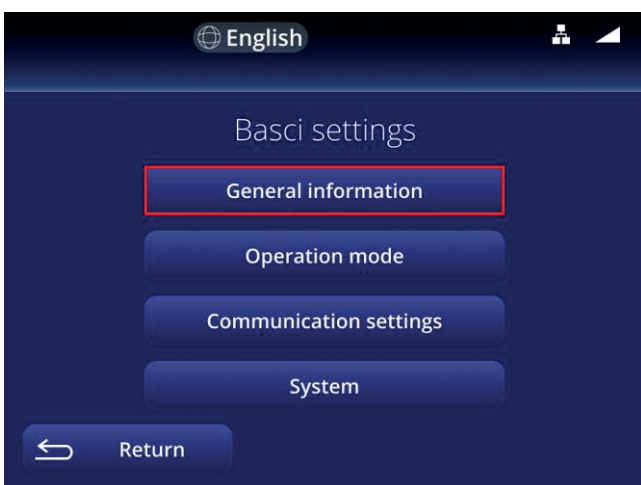
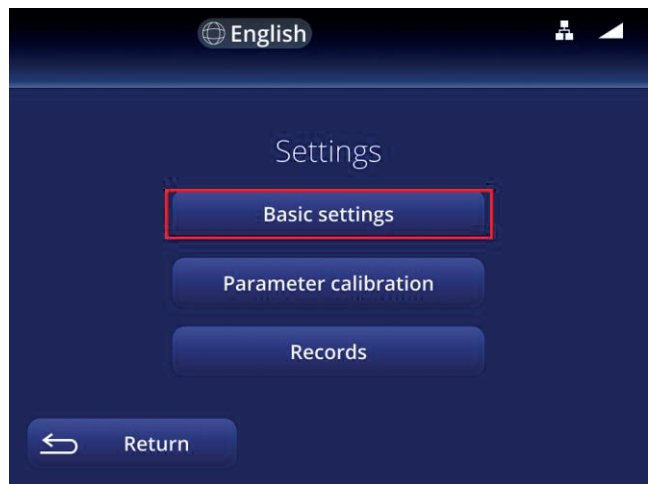
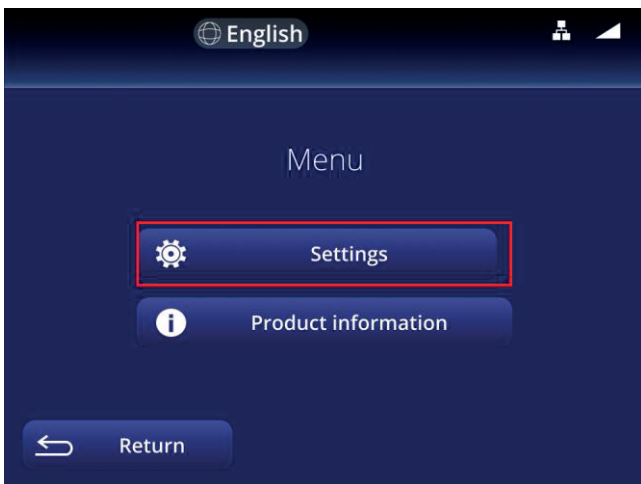
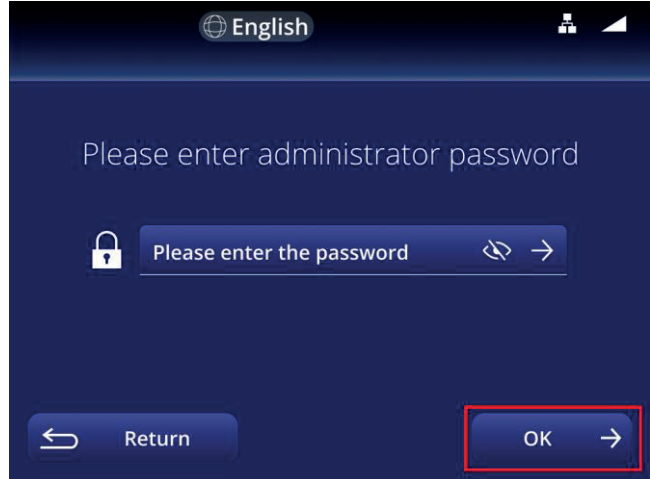
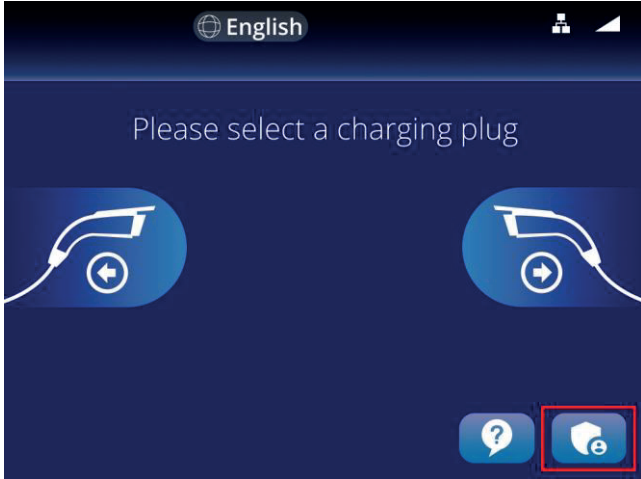

### 6.1.5. Startup Model

Admin> Enter Password>Settings> Operation mode

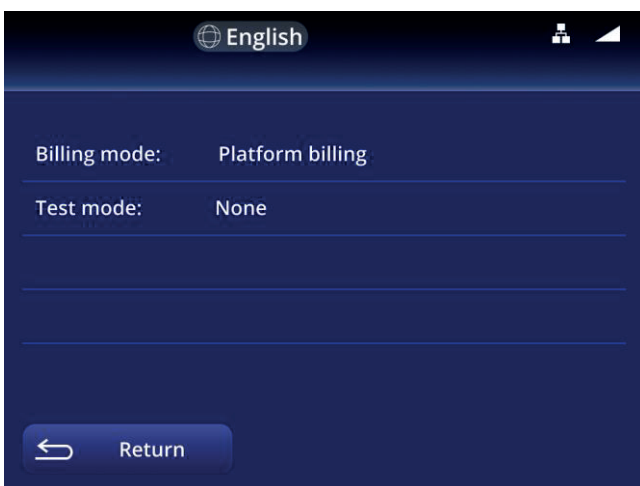
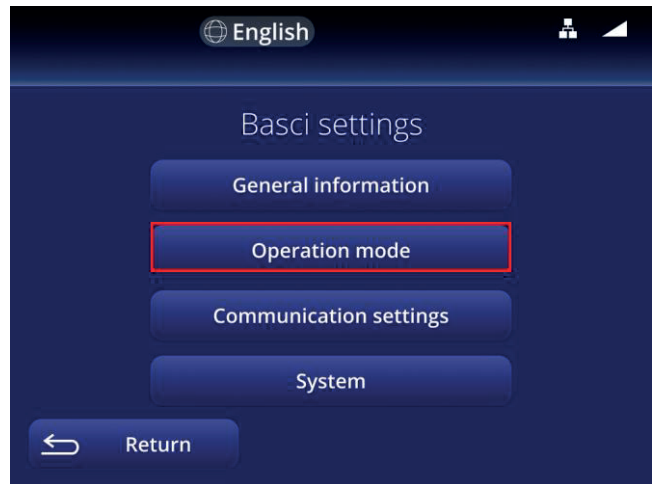
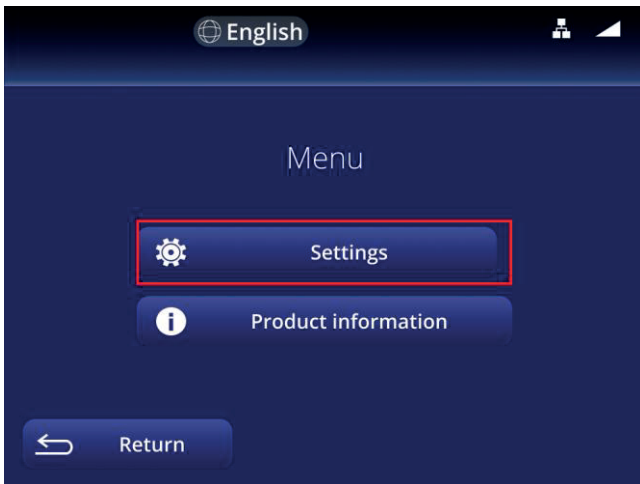
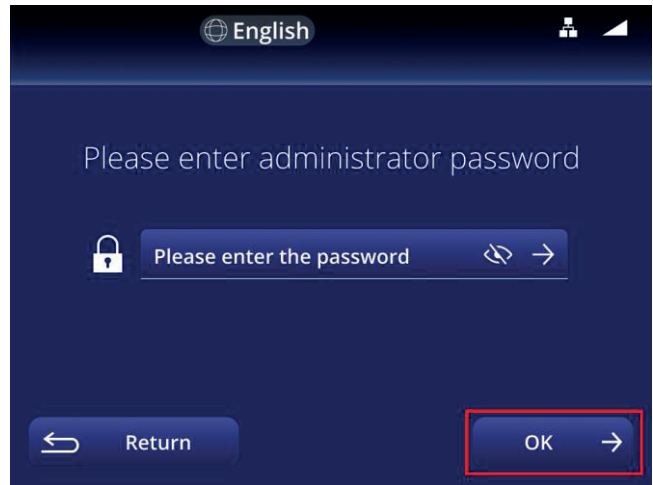
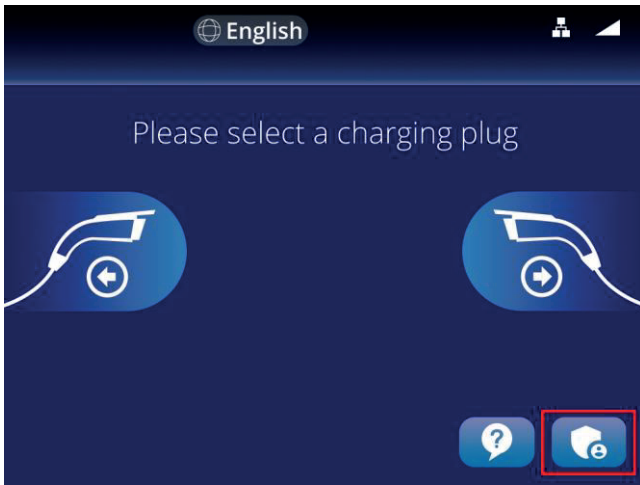

**Platform Mode**

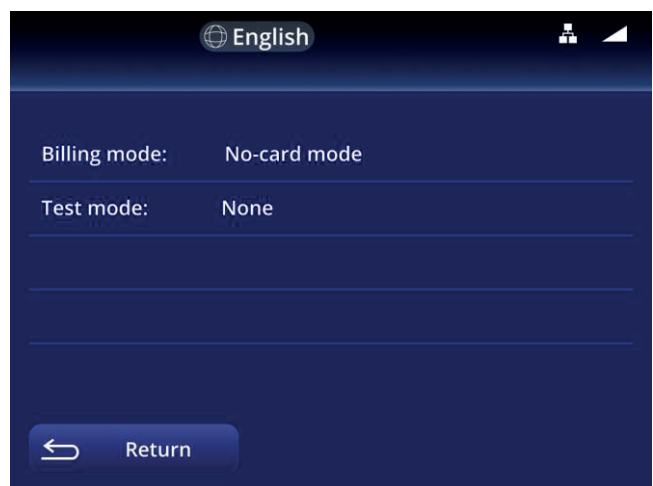

**No-card Mode**

### 6.1.6. Querying the Version Number

Admin > Enter Password > Product information

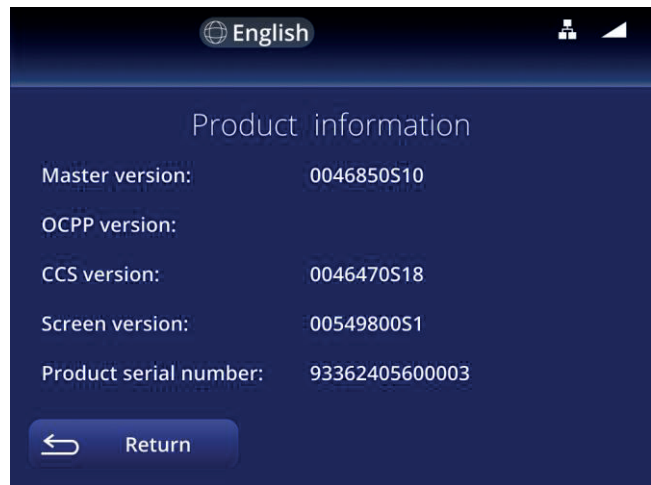
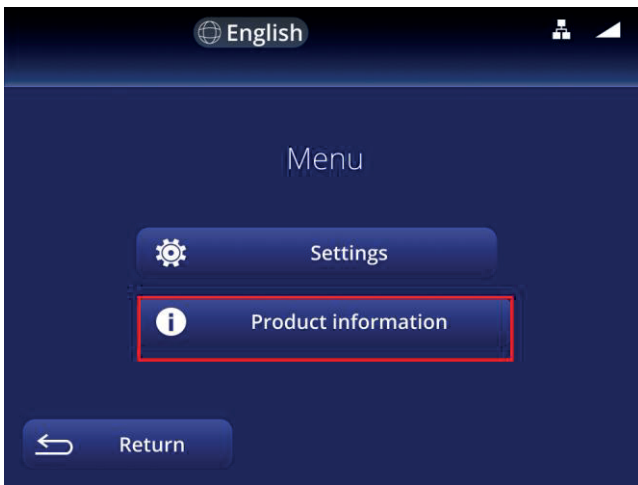
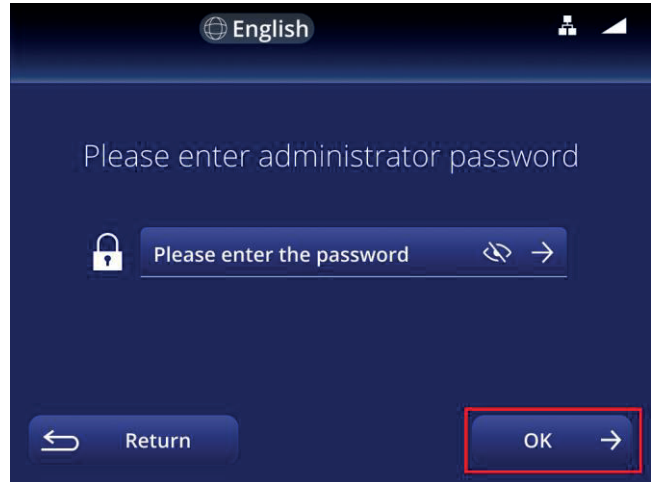
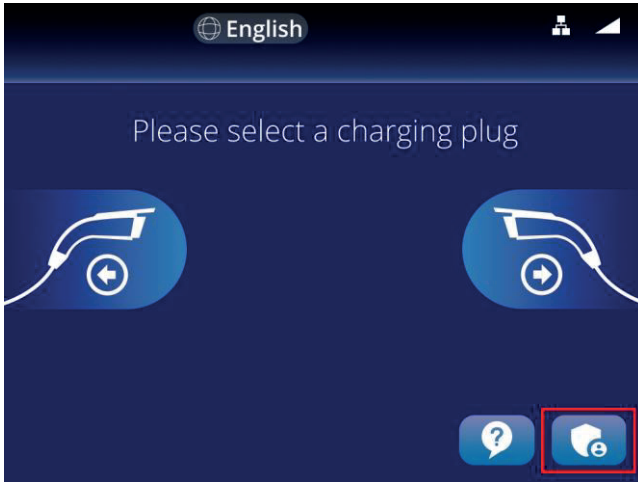

## 6.2. LED OPERATION

The front panel of the charger has an operation indication area to display the charger status.



1. Insertion indicator power LED of nozzle A When hung on the nozzle A, the power LED (green) lights up. When nozzle A is charged, the power LED (green) flashes.
2. Power LED When the charger is powered on, the power LED (yellow) will light up. When the charger is turned off, the power indicator will fade out.

3. When there is any fault or error in the charger, the fault LED (red) will light up. At this point, for safety reasons, the charger will stop running.

4. Insert nozzle indicating power LED of nozzle B. When hung on the nozzle B, the power LED (green) will light up. When nozzle B is charged, the power LED (green) flashes.

5. FC sensing area. To start or stop charging, please place the NFC card near this area.

### 6.3. PRECAUTIONS

- If the screen shows a machine failure, do not operate, please contact the staff.
- When the charging light (blue light) blinks, it is charging. At this time, please do not plug or unplug the nozzle to avoid electric shock.
- If it needs to be fully charged, please confirm that the balance of the IC card is sufficient when swiping the card. Charging will be automatically terminated if the balance is insufficient during the charging process.
- Follow the charger's operating instructions when operating.
- Be careful not to overexert when unplugging the charging cable.
- In case of emergency, please press the emergency stop switch. Charging can not be carried out at this time.

### 6.4. EPO OPERATION

When any of the following situation occurs, please press EPO button to forcibly disconnect the AC contactor, and the control receives the EPO information to forcibly stop the charging processing, and provides a warning on the screen.

- Fire alarm, electric shock or leakage occurs on this charger.
- Internal fault, can't stop charging, internal wiring problem occurs on this charger.
- It's necessary to move charger location.

**NOTE:** If you press the button by mistake, simply turn the button to the right to resume this action.

## 7. SYSTEM CONFIGURATION



**WARNING:** Configure the charger only when it is not in charging mode to avoid interrupting the charging session.

### 7.1. WIRED NETWORK SETTINGS

1. Open the front door.
2. Connect the external network cable to the second hole on the right OCPP control board.
3. Close the front door.

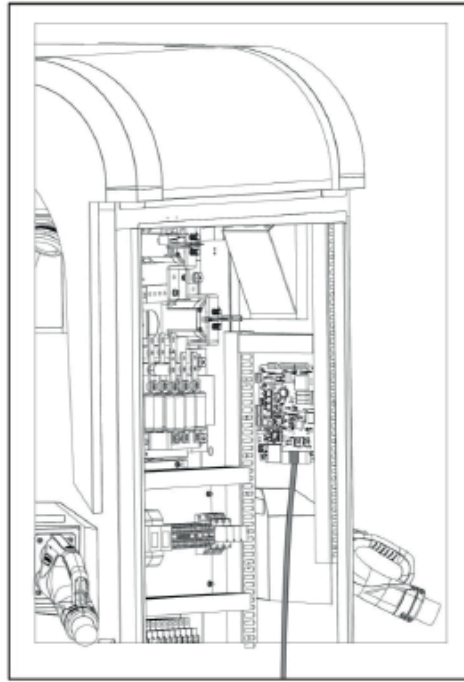

## 7.2. INTRANET SETTINGS

1. Open the front door.
2. Insert the Intranet cable.
3. Close the front door.

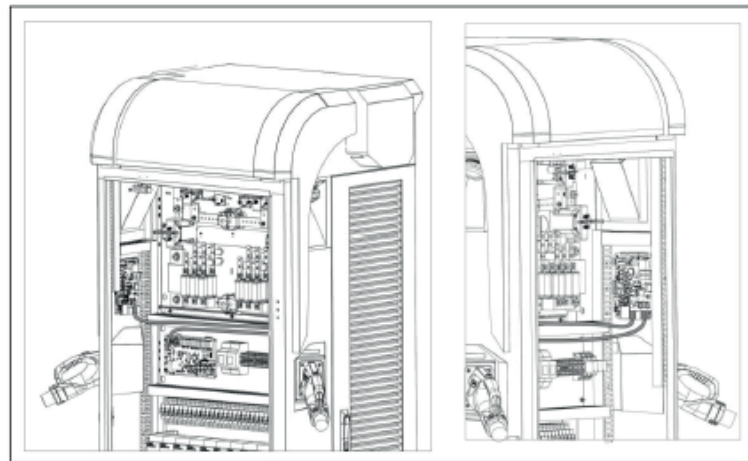

## 7.3. CELLULAR NETWORK SETTINGS

1. Open the front door.
2. Remove the SMA signal cable from the 4G-MODULE, then remove the 4G-MODULE.

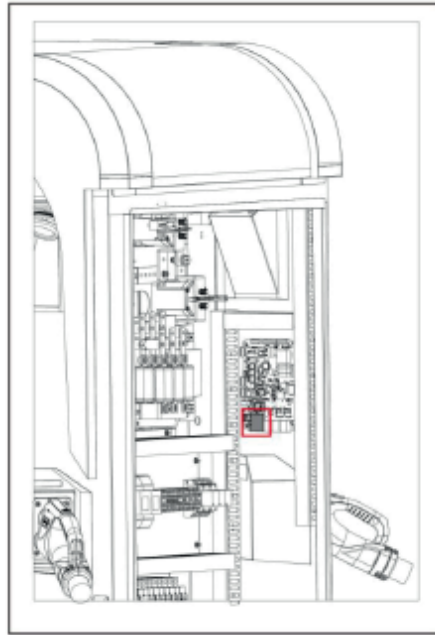

3. Insert the SIM card.

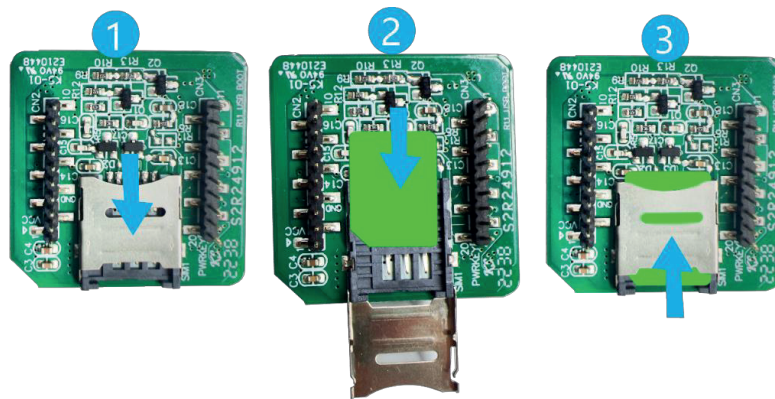

**NOTE:**  
Nano-SIM card should be selected

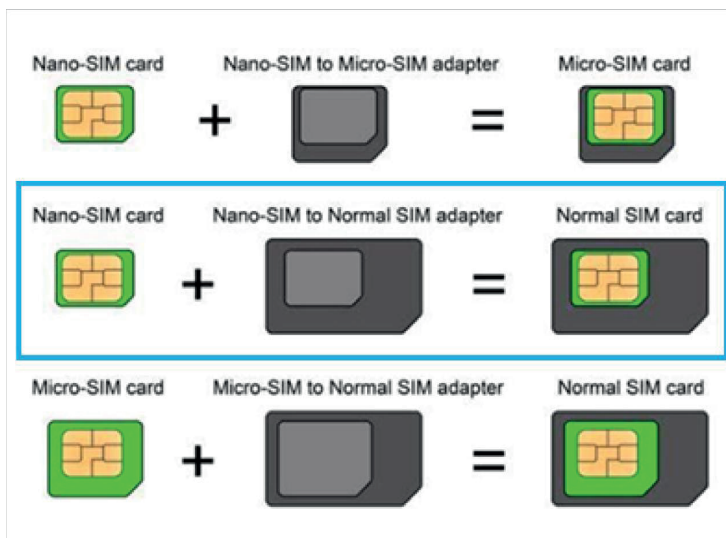

4. Connect the 4G-MODUL and SMA signal cables back to their original positions.

5. Close front door, then the SIM card is installed successfully.

6. After the charger is powered on, set up 4G.

Click : Admin > Enter Password > Settings > Basic Settings > Operation mode

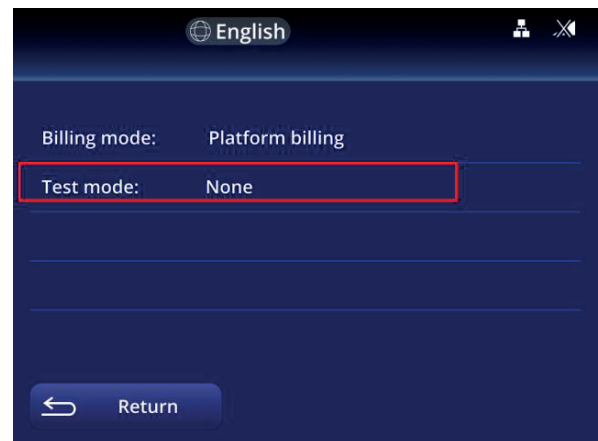
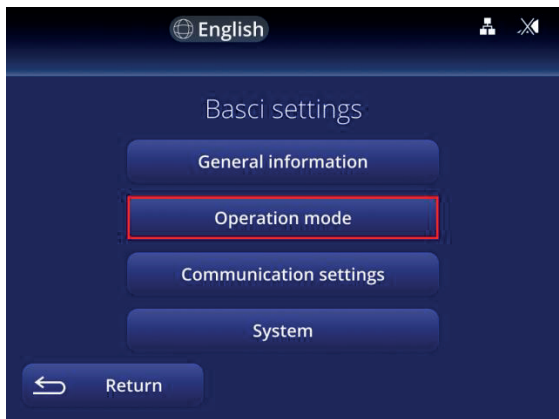
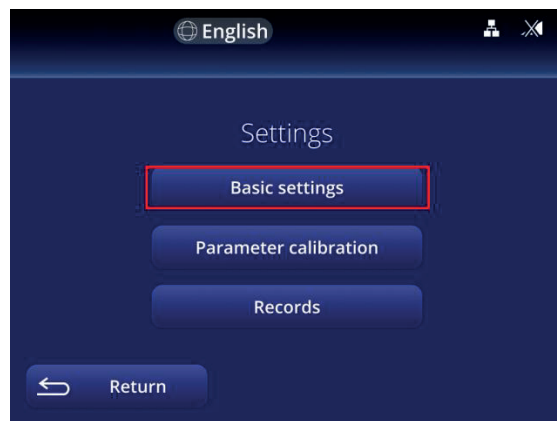
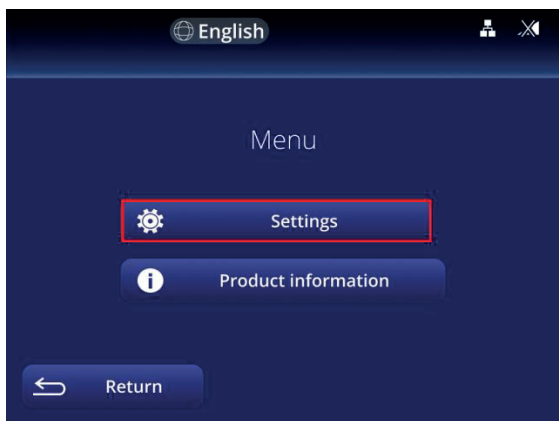
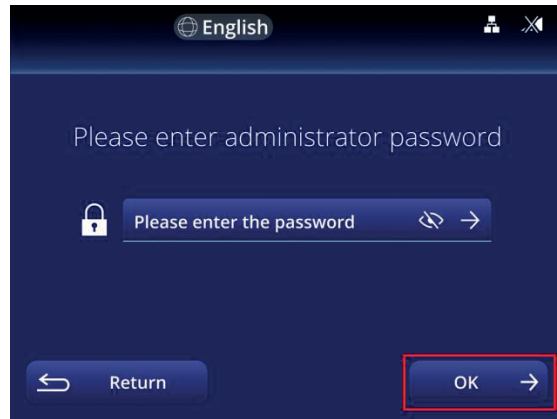
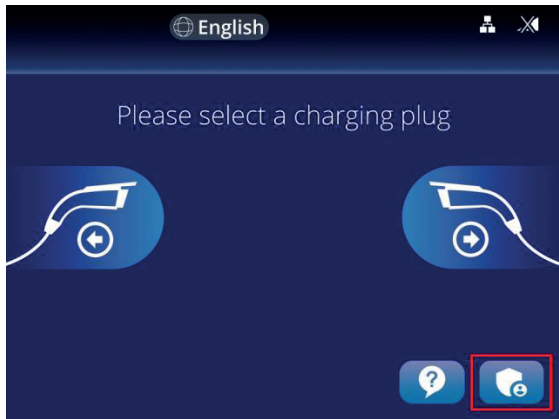

Billing mode Select "Platform billing", Test Mode select "None", set it up and click Return

Click "Return"> Communication settings



Communication Method Select "4G", click "4G Settings"



Contact the operator of the 4G card and ask them to provide the local APN and then enter the current location.

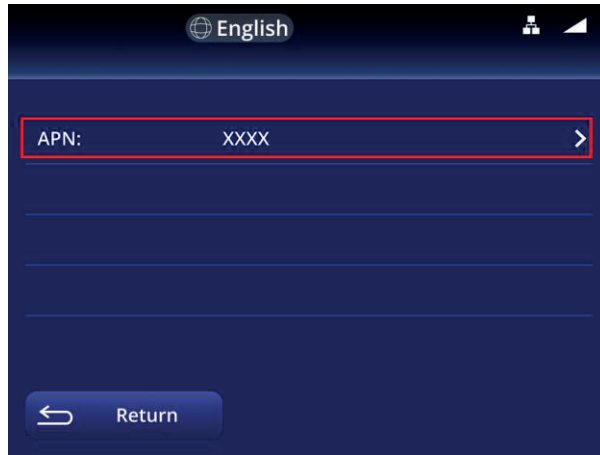

Wait 1 minute and the signal icon does not cross, which proves that the 4G module communicates successfully.



## 7.4. OCPP CONNECTION

1. Open the front door.
2. Insert the network cable to use RJ45.
3. Close the front door.

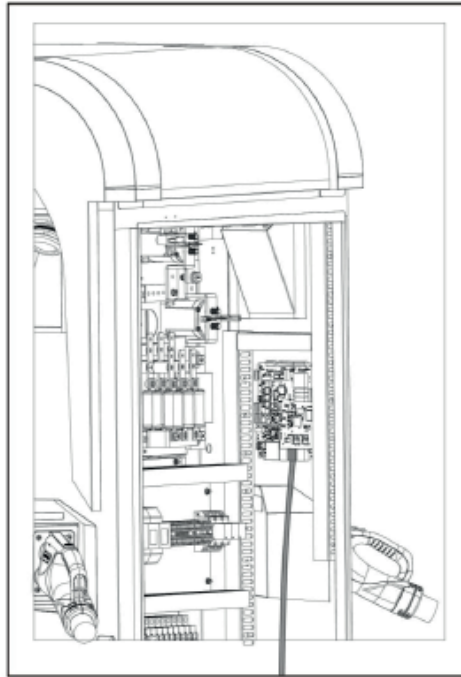

4. Click :Admin> Enter Password >Settings> Basic Settings > Operation mode

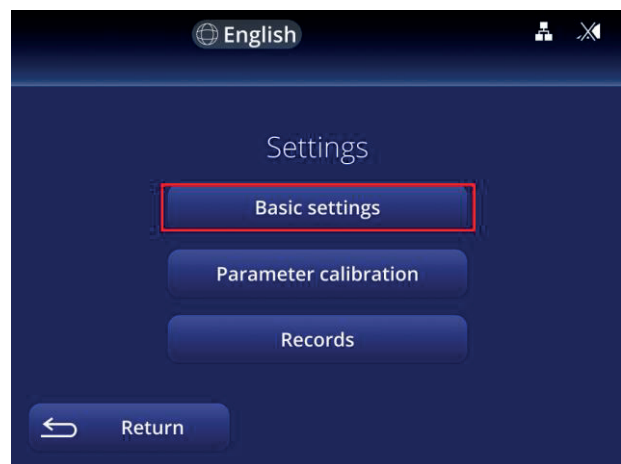
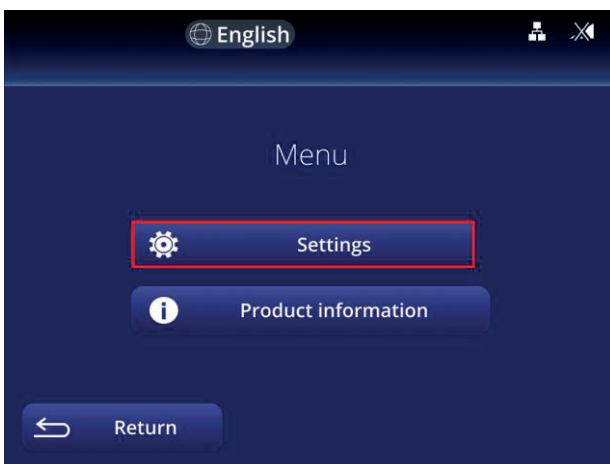
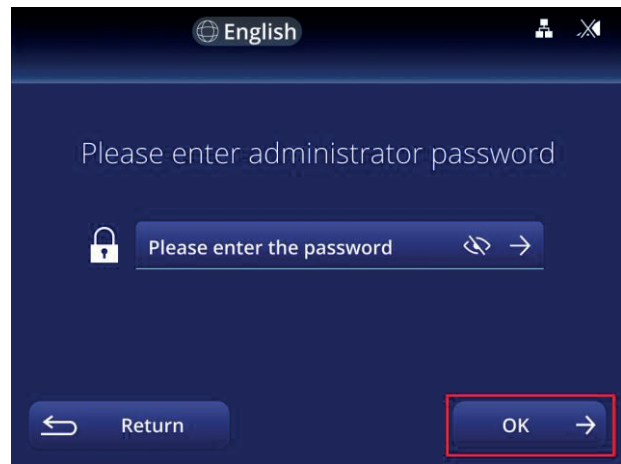
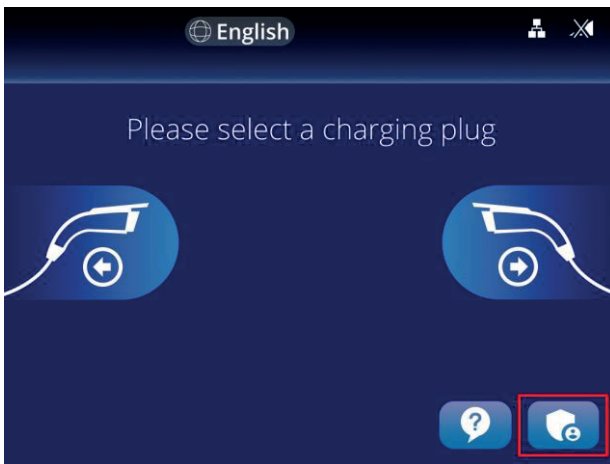

5. Billing mode Select "Platform billing", Test Mode select "None", set it up and click Return

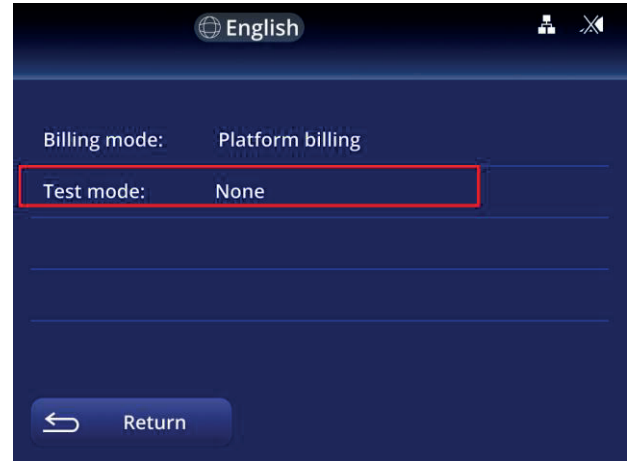

6. Click General information



7. Set the OCPP ID

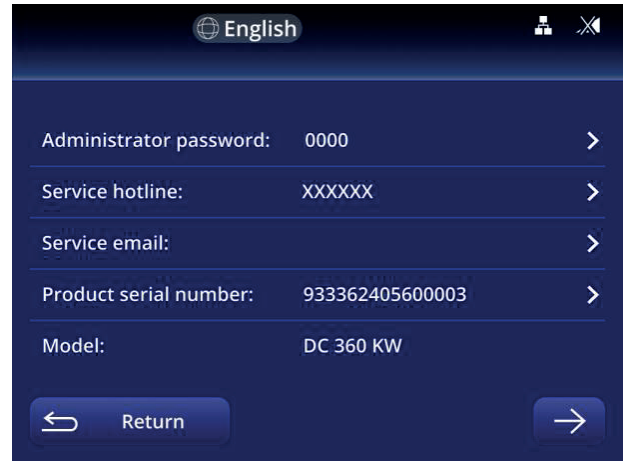

8. Click Communication settings



9. Communication Method Select "Ethernet", click "Ethernet Settings"

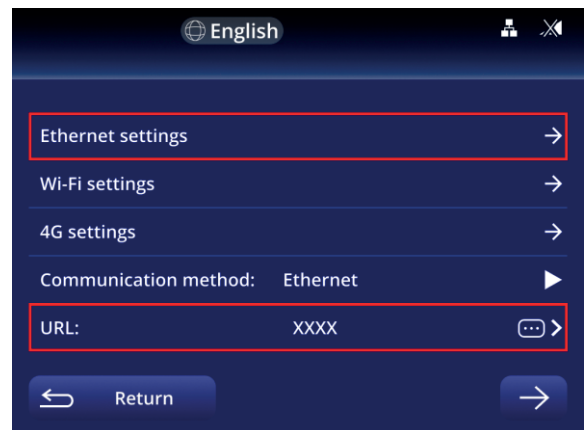

10. DHCP selects "Enable", and the URL is filled in with the cloud platform address obtained by the customer.

**NOTE:** The URL of the cloud platform and the charger must be consistent, and the URL of each platform is inconsistent, so you need to fill in the URL according to the platform used by the user.

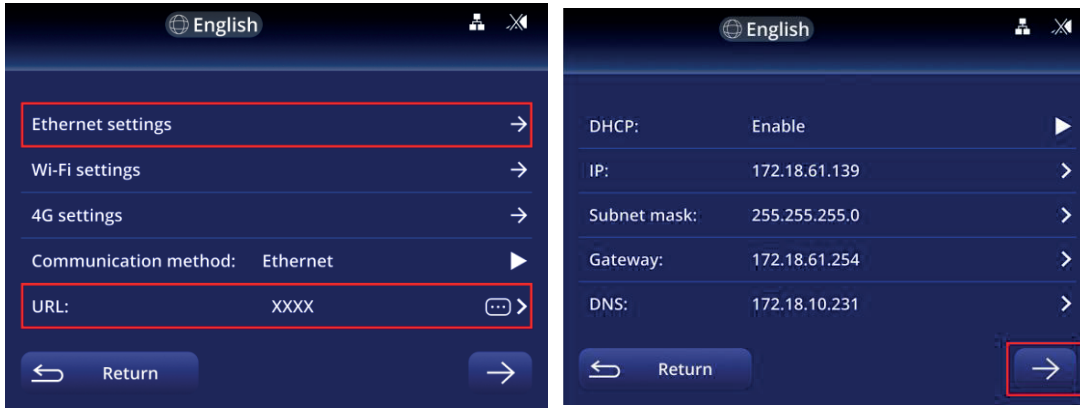

11. The MAC address does not need to be modified, and each charger has been modified by the manufacturer before leaving the factory.

**NOTE:** The MAC address is globally unique and cannot be set repeatedly.

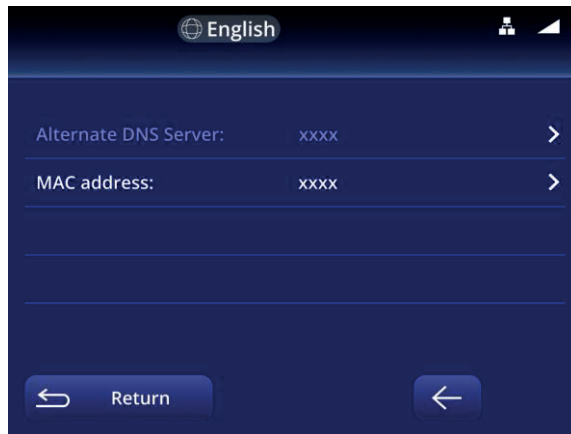

12. After the customer cloud platform is created, reboot, then wait 1~2 minutes and the signal icon does not cross, prove that the charger is successfully connected to the cloud platform.



## 7.5. CHECK MODULE SETTINGS

- Check each charging module for packing material intervention fans.
- Open the front door of the charging pile, check whether the branch circuit switch is open, and confirm that the input switch of each module is in the open state.

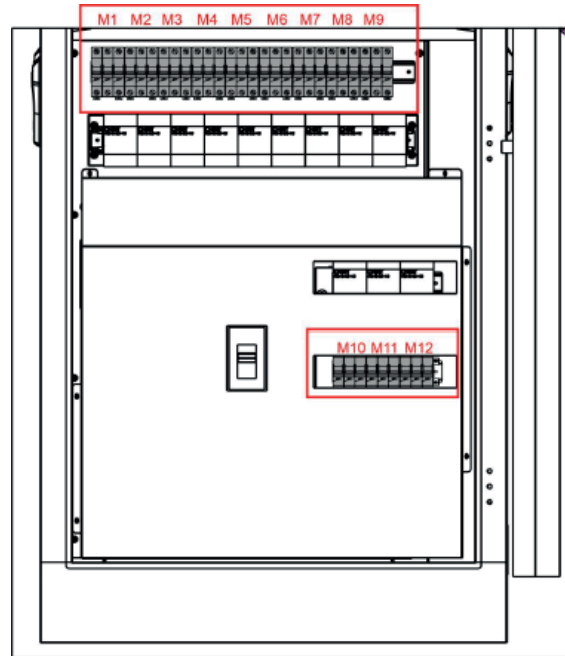

### Step 1: Check the charging module

- The dip switches are located underneath the modules and are dialed correctly according to the dip switches. 0" dialed to the left is off and "1" dialed to the right is on.
- Check that each charging module is placed and dialed correctly as shown below.

#### NOTE:

- **The module switches from left to right correspond to modules M1 to M12.**
- **Reduce capacity, reduce 360K to 300K capacity, and shut down the modules of M6 and M12.**

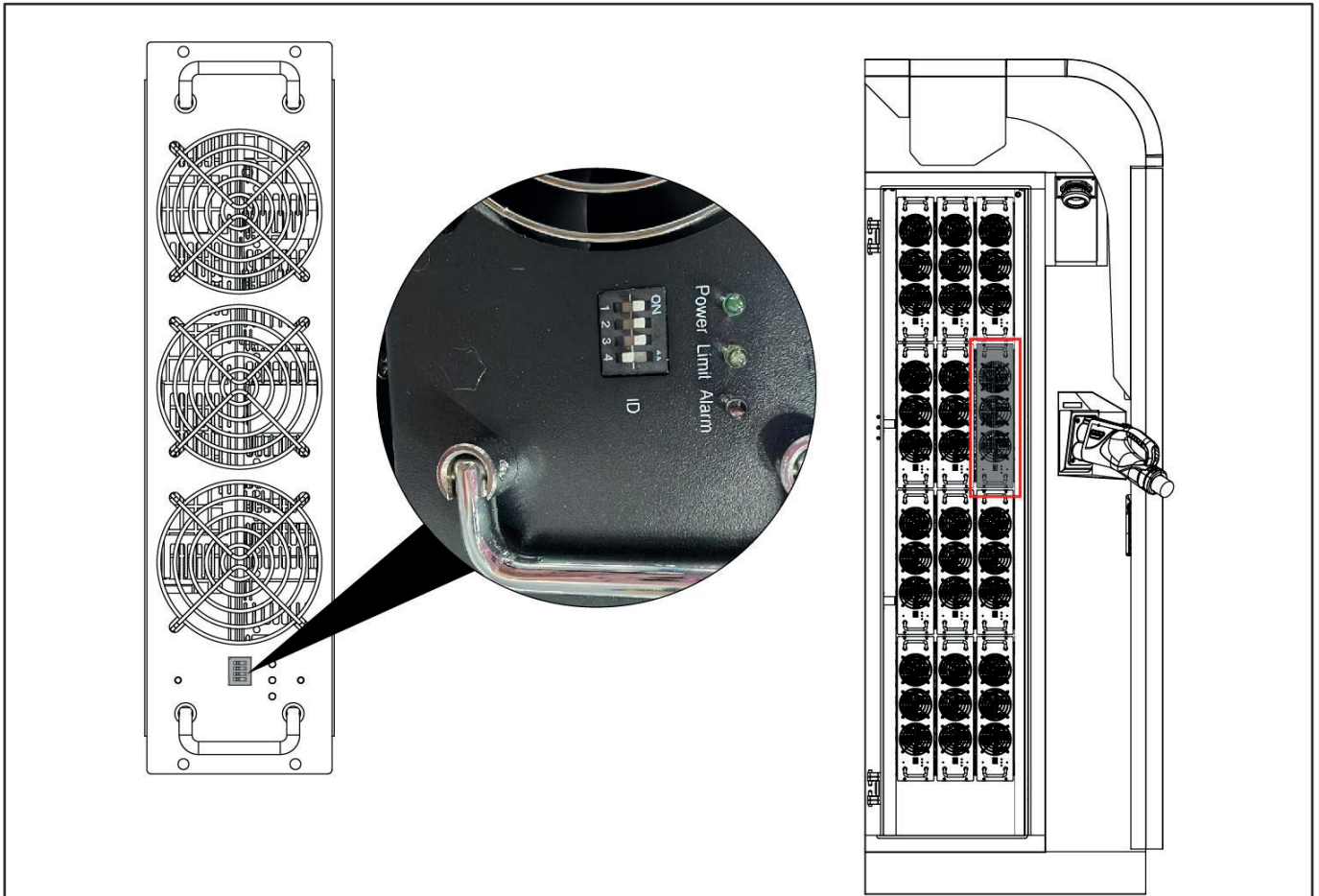

Placement drawing of DC module for 60kW, 120kW, 180kW, 240kW, 300kW, and 360kW Models

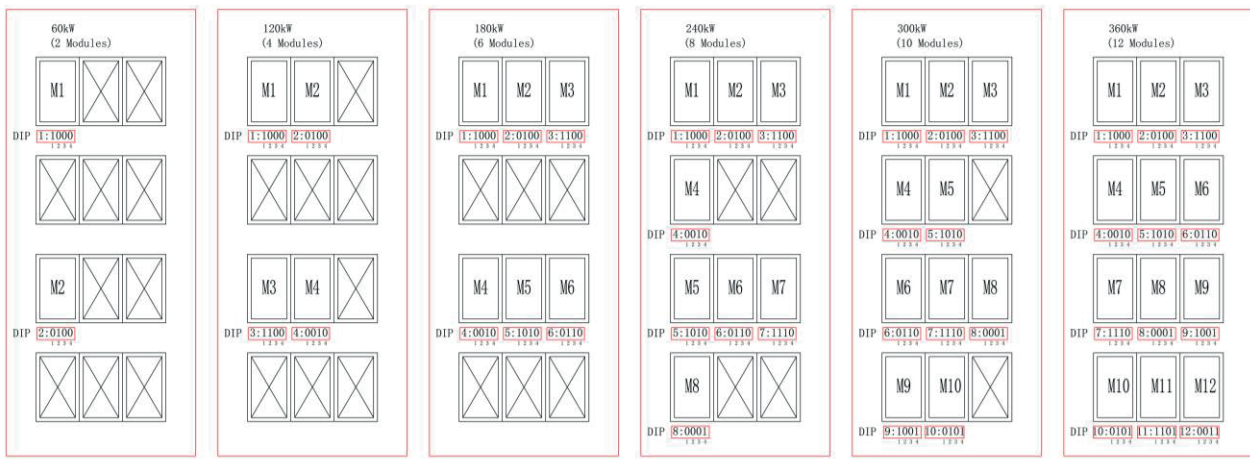

**Step 2: View the number of modules**

Click Admin> Enter Password >Settings >Basic settings >System

**NOTE: Number of rectifier modules in the display screen should be set to match the actual number used.**

Click Admin> Enter Password >Settings >Basic settings >System

**NOTE: Number of rectifier modules in the display screen should be set to match the actual number used.**

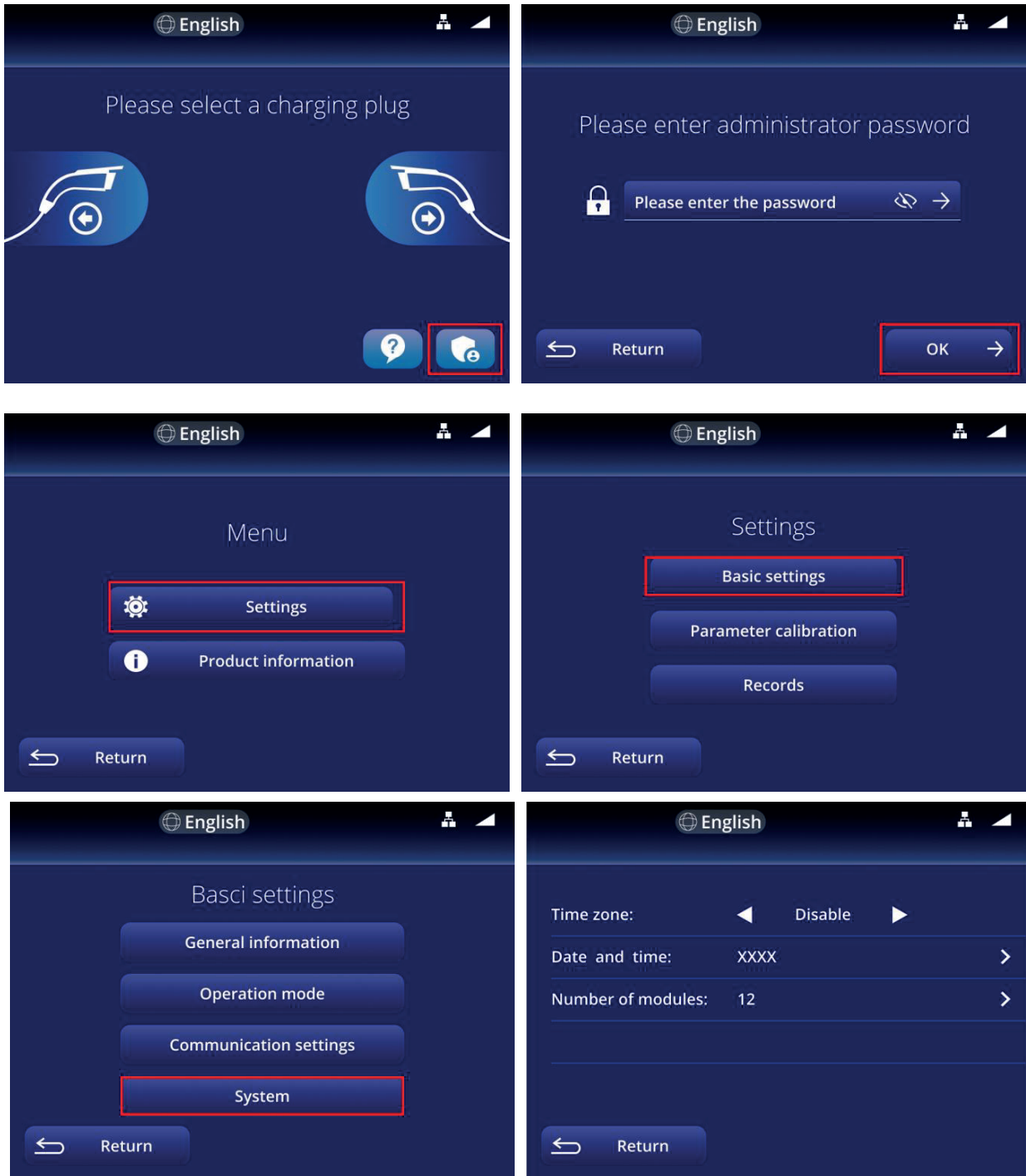

## 8. ROUTINE MAINTENANCE

Due to the influence of ambient temperature, humidity, dust and vibration, the internal devices of the charger will wear out, which leads to the potential failure of the charger. Therefore, it is necessary to carry out daily and regular maintenance of charger to ensure their normal operation and its service life.

- Regularly check if the cabinet structure is loose and sliding.
- Check if the connecting wire is worn and the charging connector is connected firmly.
- Regularly check if any internal components is damage, loose or burned out.
- Regularly check if AC incoming line and ground wire are firmly connected.
- Check the dust accumulation in the cabinet once a month and clean it in time to ensure the heat dissipation.
- Please be sure to keep the cabinet door closed and locked when nobody is on duty.

**NOTE:** Only professional electricians or persons with professional qualifications can operate the contents of this chapter.



**CAUTION:** Do not leave screws, washers and other metal parts in the charger for maintenance, otherwise the equipment may be damaged. After the completion of equipment maintenance, it is necessary to check the cabinet to ensure the normal operation of the charger.



**WARNING:** During equipment maintenance and overhaul, please be sure to cut off the AC power supply of the charger.



**WARNING:** During equipment maintenance, necessary measures shall be taken to prevent the charger from being energized by mistake.

Maintenance Projects	Maintenance Cycle
Check the function of each fan regularly: check whether there is abnormal noise and whether the fan turns smoothly.	3 months
Regularly check the function of switches: switches, contactors and other switching devices in the circuit should be regularly checked to see if there is any damage or metal corrosion.	3 months
Clean regularly: clean front and back door strainers and dustproof cotton.	3 months
Check the cable and connection regularly, check whether all the cable connection is loose, if loose, must be tightened; Check connection terminals and insulation for discoloration or peeling, replace damaged or corroded terminals, and replace damaged cables.	3 months
Check whether the warning label is firm or clear, and replace it accordingly.	3 months
Regularly check whether there is abnormal sound during the operation of the charger.	3 months
Check the emergency stop function regularly: check whether the emergency stop switch is normal.	3 months

**NOTE:** If the charger is used in a harsh environment, please carry out routine cleaning according to the actual usage.

## 9. TROUBLE SHOOTING

Alarm Code	Display Information	Trouble Shooting
1	CM_HAND_STOP	Manual stop charging
2	CM_APP_STOP	Remote stop charging
3	CM_INPUT_CONTACTOR_ACT_FAULT	Please check the input contactor
4	CM_K1K2_ACT_FAULT	Please check the output contactor
5	CM_Parallel_Contactor_FAULT	Please check the busbar contactor
6	CM_SYSTEM_RESET	System restart
8	CM_FAUSE_FAULT	Please check the fuse
9	CM_ReachSOCStop	Full charge
10	CM_LCD_COMM_ERR	Please check whether the machine software material number is compatible, if not, please burn the matching program
11	FAULT_INS_BATU_NOT_ReachSetValue	The difference between the charging voltage and the preset voltage in the insulation detection stage is greater than 5%, please contact after-sales service
13	CM_GPRS_COMM_ERROR	Please check whether the machine software material number is compatible, if not, please burn the matching program
14	ARRESTER_FAULT	Please check the lightning arrester
15	STOP_SW_ACT	Check the emergency stop button
16	AC_IN_LOST	Please check the input switch
17	DOOR_OPEN	Please close the charging station door
18	CM_MODULE_FAULT	Charging module fault, please contact after-sales service
20	CM_MODULE_CUT_ALARM	Check whether the indicators on each charging module are normal and the DIP switch is correctly configured
23	CM_CARD_NO_EXIST_ERR	The account does not exist, please check whether the card is authorized
25	CM_CHARGE_BATU_ERR	Charge overvoltage, please contact after-sales service
26	CM_INS_CHECK_ERR	Insulation fault, please contact after-sales service
27	CM_LEAK_OVERTIME	The charging module voltage drops below 60V for more than 5S, please contact after-sales service
29	CM_LINK_ERR	Wrong pilot voltage, please contact after-sales service
30	CM_TIME_END	Reach preset charging time
31	CM_MONEY_END	Reach preset charge amount of money
32	CM_ConstantValue_ERR	The storage of the startup read value parameter is abnormal, please save the default data again
33	CM_DL645_COMM_ERR	Please check the electricity meter
35	PRO_FAULT_GUN_OVER_TEMP	Charge gun overheated, please wait until the charging gun temperature returns to normal
36	PRO_AC_INPUT_OVER_VOLTAGE	AC input overvoltage, check input voltage
37	PRO_AC_INPUT_LOW_VOLTAGE	AC input undervoltage, check input voltage
38	PRO_DC_OUT_OVER_VOLTAGE	Output overvoltage, please reset the charging gun output voltage
39	PRO_DC_OUT_UNDER_VOLTAGE	Output undervoltage, please reset the charging gun output voltage

<b>40</b>	PRO_DC_OUT_OVER_CURRENT	Output overcurrent, please reset the charging gun output current
<b>42</b>	FAN_RUN_FAIL	Please check the fan
<b>43</b>	WATER_SENESING_FAIL	Please check if there is water entering the machine
<b>44</b>	CM_INS_COMM_ERR	Insulation fault, please contact after-sales service
<b>45</b>	CM_ACinput_COMM_ERR	Please check if the communication line of the electricity meter is disconnected
<b>46</b>	PRO_AC_INPUT_FREQ_OUT	Input frequency is out of range, please check the input frequency
<b>47</b>	PRO_ACinput_LOSS_PHASE	Please check the input phase line
<b>48</b>	PRO_PHASE_ERROR	Please check the input phase sequence
<b>49</b>	PRO_LOSS_PE	Please check if PE is lost
<b>80</b>	EV_COM_CLOSE	Vehicle communication off, please draw your gun and try again
<b>81</b>	EV_OS_ERR	Communication board system error, please contact after-sales service
<b>82</b>	EV_HANDSHAK_FAIL	Communication handshake failure, please draw your gun and try again
<b>83</b>	EV_QCA_ERR	QCA failure, please contact after-sales service
<b>84</b>	EVSE_CERT_ERR	Charging pile certificate error, please contact after-sales service
<b>85</b>	CHG_VER_NOT_MATCH	Please check whether the machine software material number is compatible, if not, please burn the matching program
<b>86</b>	COM_ERR	Please check all communication lines
<b>87</b>	GHG_PARTER_NOT_MATCH	Charging parameter mismatch, please contact after-sales service
<b>88</b>	EV_CERT_ERR	Vehicle certificate error
<b>89</b>	COM_TIMER_OUT	Vehicle-pile communication timeout, please draw your gun and try again
<b>90</b>	UNSUPPORT_PROTEL	Unsupported protocol
<b>91</b>	CP_STATUS_ABNORMAL	CP signal anomaly, please contact after-sales service
<b>92</b>	POWER_NOT_APPLIED	Pile not charging, please draw your gun and try again
<b>93</b>	EV_METER_ERR	Vehicle metering error, please draw your gun and try again
<b>94</b>	CM_BMS_STOP	Vehicle active stop charging
<b>95</b>	CM_BMS_PAUSE	Vehicle charging suspension
<b>96</b>	EVSE_STOP	Charging pile active stop charging
<b>98</b>	CM_INS_CHECK_ALARM	Insulation fault, please contact after-sales service
<b>99</b>	CM_COMM_OVERTIME	DC power module malfunction, please contact after-sales service
<b>100</b>	CM_INPUT_OVER	DC power module malfunction, please contact after-sales service
<b>101</b>	CM_INPUT_UNDER	DC power module malfunction, please contact after-sales service
<b>102</b>	CM_FW_ERROR	DC power module malfunction, please contact after-sales service

<b>103</b>	PRO_DC_OUT_OVER_CURRENT	DC power module malfunction, please contact after-sales service
<b>104</b>	FAN_RUN_FAIL	DC power module malfunction, please contact after-sales service
<b>105</b>	WATER_SENESING_FAIL	DC power module malfunction, please contact after-sales service
<b>106</b>	CM_INS_COMM_ERR	DC power module malfunction, please contact after-sales service
<b>107</b>	CM_ACinput_COMM_ERR	DC power module malfunction, please contact after-sales service
<b>108</b>	PRO_AC_INPUT_FREQ_OUT	DC power module malfunction, please contact after-sales service
<b>109</b>	PRO_ACinput_LOSS_PHASE	DC power module malfunction, please contact after-sales service
<b>110</b>	PRO_PHASE_ERROR	DC power module malfunction, please contact after-sales service
<b>111</b>	PRO_LOSS_PE	DC power module malfunction, please contact after-sales service
<b>112</b>	EV_COM_CLOSE	DC power module malfunction, please contact after-sales service
<b>113</b>	EV_OS_ERR	DC power module malfunction, please contact after-sales service
<b>114</b>	EV_HANDSHAK_FAIL	DC power module malfunction, please contact after-sales service
<b>115</b>	EV_QCA_ERR	DC power module malfunction, please contact after-sales service
<b>116</b>	EVSE_CERT_ERR	DC power module malfunction, please contact after-sales service
<b>117</b>	CHG_VER_NOT_MATCH	DC power module malfunction, please contact after-sales service
<b>118</b>	COM_ERR	DC power module malfunction, please contact after-sales service
<b>119</b>	GHG_PARTER_NOT_MATCH	DC power module malfunction, please contact after-sales service
<b>120</b>	EV_CERT_ERR	DC power module malfunction, please contact after-sales service
<b>121</b>	COM_TIMER_OUT	DC power module malfunction, please contact after-sales service
<b>122</b>	UNSUPPORT_PROTEL	DC power module malfunction, please contact after-sales service
<b>123</b>	CP_STATUS_ABNORMAL	DC power module malfunction, please contact after-sales service
<b>124</b>	POWER_NOT_APPLIED	DC power module malfunction, please contact after-sales service
<b>125</b>	EV_METER_ERR	DC power module malfunction, please contact after-sales service
<b>126</b>	CM_BMS_STOP	DC power module malfunction, please contact after-sales service
<b>127</b>	CM_BMS_PAUSE	DC power module malfunction, please contact after-sales service
<b>128</b>	EVSE_STOP	DC power module malfunction, please contact after-sales service
<b>129</b>	CM_INS_CHECK_ALARM	DC power module malfunction, please contact after-sales service
<b>130</b>	CM_COMM_OVERTIME	DC power module malfunction, please contact after-sales service
<b>131</b>	CM_INPUT_OVER	DC power module malfunction, please contact after-sales service
<b>132</b>	CM_INPUT_UNDER	DC power module malfunction, please contact after-sales service